



SPINFLO

操作手冊

Instruction Manual

台灣旋流科技有限公司
TAIWAN SPINFLO CO., LTD.

一、概 要.....	01
二、安裝規範.....	01
1.載運須知.....	01
2.安裝條件及環境限制.....	02
3.用油限制.....	03
4.管路系統配置.....	03
5.電路系統配置.....	04
三、操作規範.....	09
1.操作前檢查及準備動作.....	09
2.操作程序及運轉中檢查.....	09
3.控制器介紹.....	10
四、保養規範.....	12
五、故障排除.....	13
1.單螢幕電子顯示溫度控制.....	15
■ AL-1 REV 欠相、逆相.....	15
■ AL-2 PUMP 馬達泵浦異常.....	16
■ AL-3 COMP(Compressor)壓縮機馬達異常.....	17
■ AL-4 RA(Room Temperature)室溫探測棒異常.....	19
■ AL-5 RO(liquid Temperature)液溫探測棒異常.....	20
■ AL-6 OT(Over Temperature)液溫過高.....	20
2.雙螢幕電子顯示溫度控制.....	21
■ AL-1 REV 欠相、逆相.....	21
■ AL-2 OPS(Oil Pressure Switch)液壓迴路異常.....	22
■ AL-3 PUMP 馬達泵浦異常.....	23
■ AL-4 COMP(Compressor)壓縮機馬達異常.....	23
■ AL-5 HP(High Pressure)冷媒高、低壓力異常.....	24
■ AL-6 RA(Room Temperature)室溫探測棒異常.....	24
■ AL-7 RO(liquid Temperature)液溫探測棒異常.....	24
■ AL-8 OT(Over Temperature)液溫過高.....	25
■ AL-9 LT(Low Temperature)液溫過低.....	25
☆售後服務保證書.....	52

一、概要

1. 首先感謝貴公司使用本公司油冷卻機產品，目前此系列產品大致可分為PS(不含油箱機型)及PTS(含油箱機型)，配置方式如下，PTS機型應用於工具機主軸及滑軌部分，PS機型則應用於齒輪箱及工具機工作油箱內。
2. 油冷卻機已普遍應用於CNC平面磨床、CNC綜合切削中心機、CNC快速車床、CNC木工雕刻機、CNC油壓機械、CNC銑床沖床等機械，有效達到主軸潤滑與冷卻。使用油冷卻機能使工作母機在長期運轉使用下，主軸系統仍然能保持最佳油溫，延長工作時數，提高工作效益，並維持加工物件尺寸之精準度。
3. 安裝配置圖方式，如(圖1)所示。



圖1

二、安裝規範

1. 載運須知：

- (1) 安置及搬運過程中盡量將冷卻機直立放置，並避免傾斜角度超過 45° ，如(圖2)所示。
- (2) 移動冷卻機前，請先拆除電源連線並將系統內之冷卻液移除。
- (3) 使用堆高機搬運應確保冷卻機處於平衡狀態距離地面距離保持在20公分之內，如(圖3)所示。

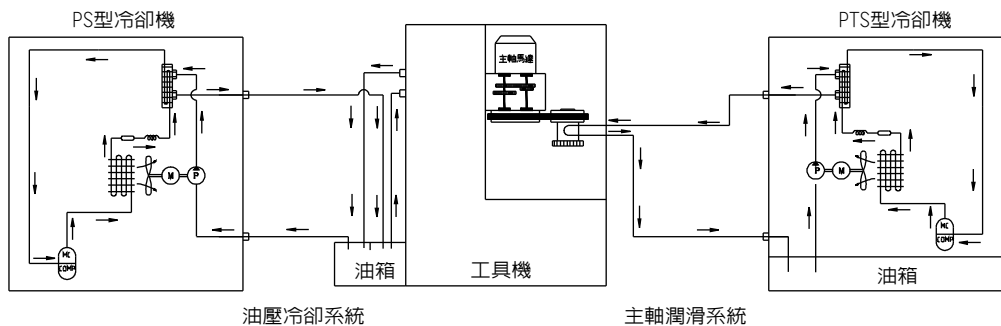

圖2



圖3

(4) 使用天車移動冷卻機。

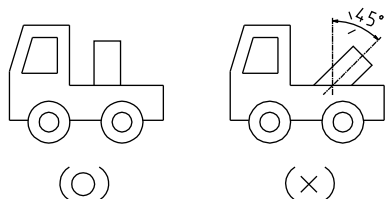
- 請選擇足夠支撐冷卻機重量的天車與繩索使用，重量請參考冷卻機版左側的銘版 (WEIGHT) 數值，如(圖4)所示。
- 請保持冷卻機平衡並避免碰撞或撞擊。
- 移動冷卻機時，所有工作人員須和天車保持安全距離。

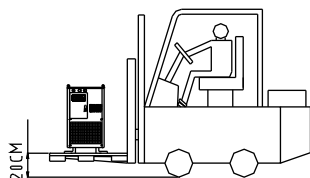

圖4

2. 安裝條件及環境限制：

- (1) 本冷卻機的建議設定溫度範圍在 $25^{\circ}\text{C}\sim 35^{\circ}\text{C}$ ，而使用的環境溫度在 $5^{\circ}\text{C}\sim 40^{\circ}\text{C}$ ，以維持正常的冷卻能力。
- (2) 冷卻機安裝時，請選擇通風良好及遠離灰塵的地方。
- (3) 冷卻機安裝時，請選擇安裝於地面水平位置，嚴禁傾斜放置。
- (4) 本冷卻機嚴禁安裝在容易被水噴灑到的場所。
- (5) 冷卻機周圍，請勿堆放物品，以免堵塞通風及排風口會造成冷卻機過熱導致跳機，如(圖5)所示。
- (6) 請盡量避免安置於戶外，或有陽光直接照射處，避免安置有熱源的場所。

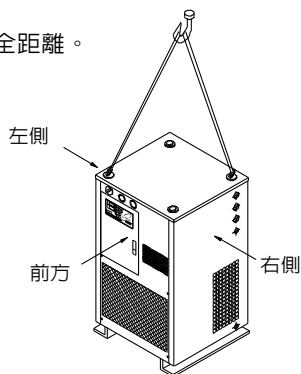
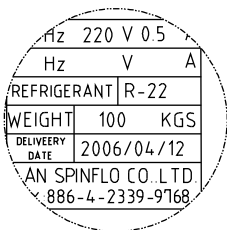

圖5

3. 用油限制：

- (1) 本冷卻機適用礦物系之油壓油和潤滑油，嚴禁使用其他冷卻液，如水、乙二醇...等（建議使用油品番號32及68號油）。
- (2) 使用的油料黏度過高或過低時，泵浦將可能產生不正常的聲響或影響降溫效果，此時請更換適當黏度的油料。
- (3) 油料黏度變化參考圖，如(圖6)所示。

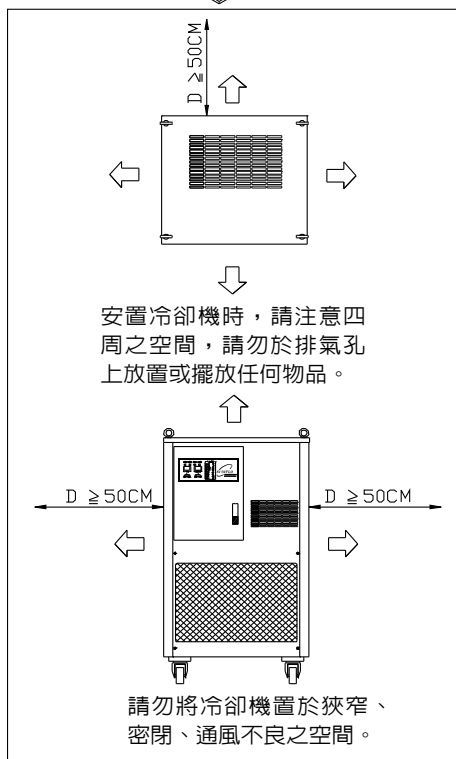

圖6

4. 管路系統配置：

- (1) 安置冷卻機時，請盡量選擇靠近您的機台處，以便縮短管路長度，避免增加管損產生壓力損耗及冷卻能力不足的現象。
- (2) 本機型為冷卻機，接頭部分可選用不鏽鋼、銅或鐵等材質的管材安裝。
- (3) 安裝管材前，請將管材內部使用噴槍清理。
- (4) 冷卻機的進出口與您所選用的進出口管徑不可差異過大，否則長期時間會間接影響冷卻機壽命，如(表1)所示。

單位 \ 型號	40	60	80	100	120	180	240	360	480	600	900	1200
進口	inch 1/2"	3/4"	3/4"	3/4"	3/4"	3/4"	3/4"	1"	1"	1"	1 1/4"	1 1/2"
建議使用管徑	inch ≥1/2"	≥3/4"	≥3/4"	≥3/4"	≥3/4"	≥3/4"	≥3/4"	≥1"	≥1"	≥1"	≥1 3/4"	≥1 1/2"

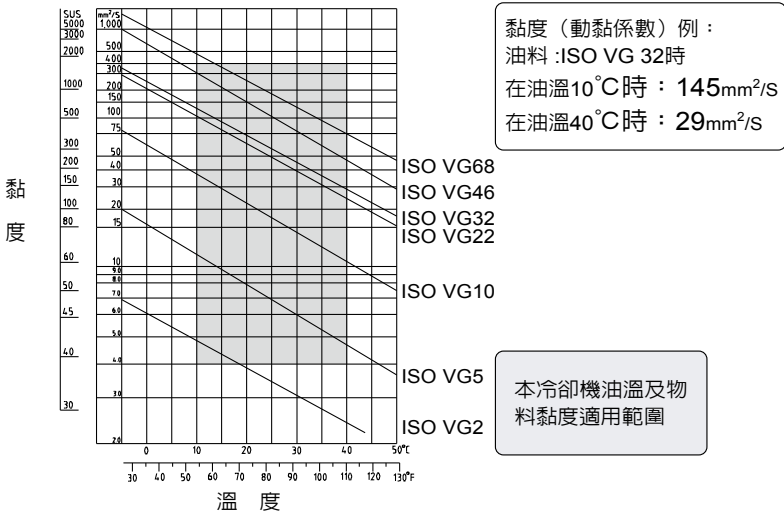
註：若本機為PS系列，冷卻機的進口管徑嚴禁安裝比標準配備管徑小的管材。

- (5)請於管路配置前，先確認進口、出口、排液口及補給口位置，再正確安裝相關位置。
註：機台所標示之進出口位置，會依機型而有所不同，配置管路前，需依實物上所標示之位置及功能做確認。
- (6)安裝進出口時，請使用止洩帶繞緊牙口，並確認是否正確垂直鎖入孔內，並以 $150\text{kg}/\text{cm}^2$ 以下之壓力鎖緊，以防止漏油。
- (7)配管時請盡量避免管路彎曲，並減少使用閥門，避免影響流量及壓力。
- (8)管路放置路線，應盡量避免與其他外露電器用品重置，以免發生漏電現象。

5. 電路系統配置：

- (1)在裝配電源部分時，須確實注意您所訂購機台上之銘板內容規格(電壓、相位、型號..) 是否與工廠電壓相符，以免造成不必要之毀損。
- (2)使用接地線時，接地線必須為黃綠線，接地螺絲也必須使用有齒狀可咬住鐵板，破壞烤漆阻隔，以確切預防漏電時無法排除，產生危險。
- (3)電力接點及故障接點和遠控接點端子台圖示說明，如(圖8)所示。



圖8

● R.S.T.為電源接點：

當冷卻機入力電源時，大、小型基板皆有三相逆相、欠相檢知功能。

例：當相序為逆相序時，小基板故障燈會亮且螢幕顯示AL-1，而大基板逆相時故障燈會亮且螢幕顯示AL-1。此時只需將接電力線R、T的線對換，即可排除ALARM。

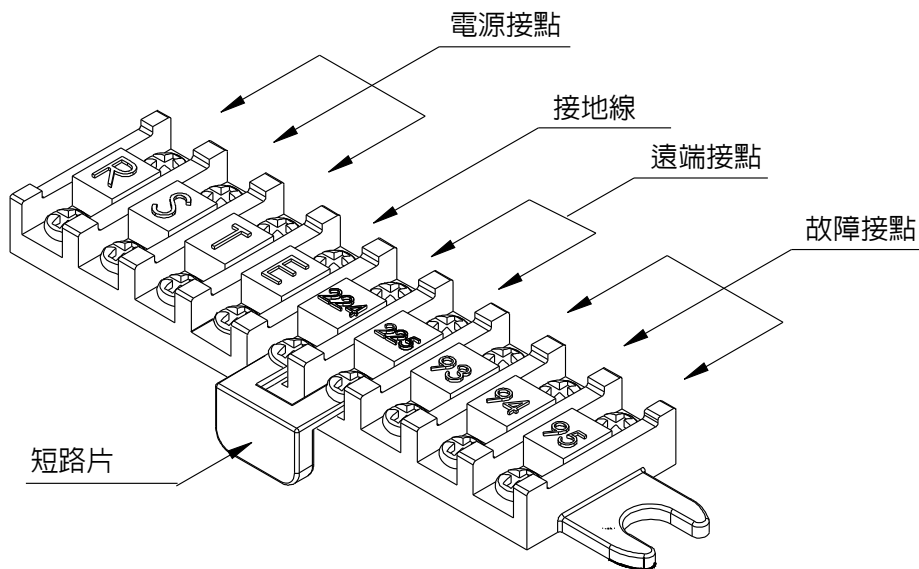
● E為黃綠色接地線：

● 93.94.95為故障接點：

本公司標準機型是提供客戶端接93、95故障接點，而冷卻機在正常運轉的情況下，93、95為 b 接點，而93、94為 a 接點，一但冷卻機產生ALRAM時，或冷卻機完全無入電時，或是冷卻機有電源而未啓動運轉的情況下，93、95會轉變為a 接點，而93、94為 b 接點，以警示客戶端，通知冷卻機異常，如(表2)所示。(若您機台不適用，請將94,95對調既可)。

線 號	正常運動中		出現故障時	
93.95				
93.94				

表2

● 224.225為遠控接點：

此遠控接點可與工作機台連線，做為控制冷卻機啓動與停止，224及225平常出廠時都是呈短路狀態，除非使用者有需要，才能將224和225之短路片拆掉，外接連結線至工作機台控制器上之 b 接點，便可直接控制冷卻機運轉與停止。

(4) 圖 9 和圖 10 為標準配電圖：

● MO338單螢幕溫度控制器配電圖(即SA系列小機板)，如(圖9)所示。



圖9

51P 泵浦馬達電磁開關

51C O.L.壓縮機馬達過載保護器

51C 壓縮機馬達電磁開關

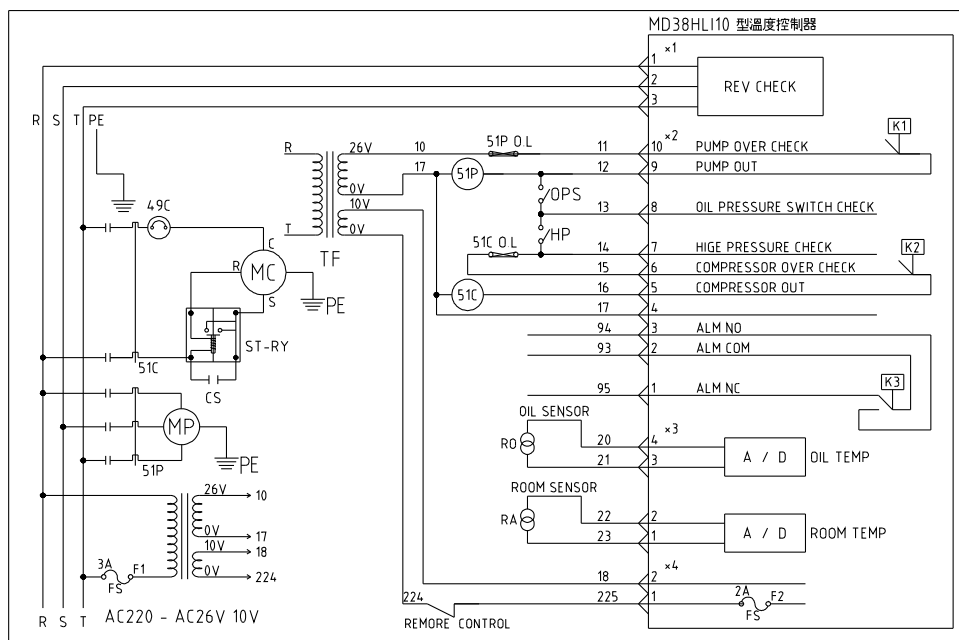
51P O.L.泵浦馬達過載保護器

RO 液溫感測線

RA 室溫感測線

MP 泵浦馬達

MC 壓縮機馬達

PE 接地線

49C 壓縮機內置過載保護器

OPS 油壓開關

CS 啟動電容

TC 運轉電容器

FS 保險絲

HP 高壓開關

ST-RY 啟動電譯

TF 變壓器

● MO332雙螢幕溫度控制器配電圖(即S系列大機板)，如圖(10)所示。



圖10

- | | | | |
|-------------------|----------------|----------|------------|
| 51P 泵浦馬達電磁開關 | RA 室溫感測線 | OPS 油壓開關 | ST-RY 啟動電譯 |
| 51C O.L壓縮機馬達過載保護器 | MP 泵浦馬達 | CS 啟動電容 | TF 變壓器 |
| 51C 壓縮機馬達過載保護器 | MC 壓縮機馬達 | TC 運轉電容器 | |
| 51P O.L泵浦馬達過載保護器 | PE 接地線 □ | FS 保險絲 | |
| RO 液溫感測線 | 49C 壓縮機內置過載保護器 | HP 高壓開關 | |

(5) 圖11為配電箱內各電子零件的相對位置參考圖：

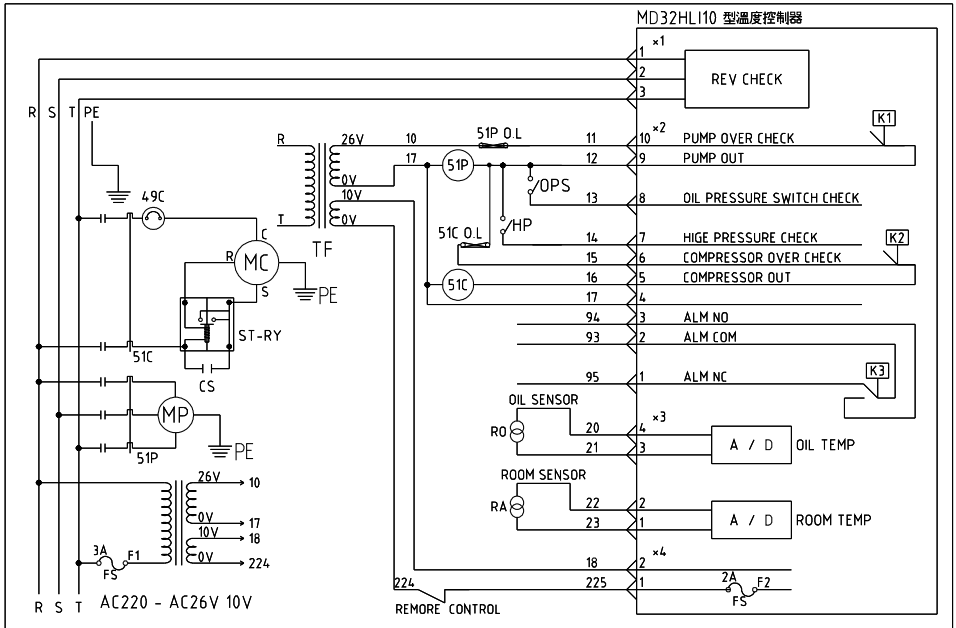

圖11

三、操作規範

1. 操作前檢查及準備動作：

- (1) 檢查電源接通時，面板上的POWER燈是否亮起？
- (2) 若本機有配備冷煤高低壓力錶，請檢查低壓力錶是否於50~150psi之間？
- (3) 檢查油水管路是否正確安裝於冷卻機進出口的位置？如(圖12)所示。
- (4) 當本機有配備油箱時，補給液體時、檢查油箱是否於正常油位(HIGH與LOW之間)？嚴禁馬達空轉，如(圖13)所示。

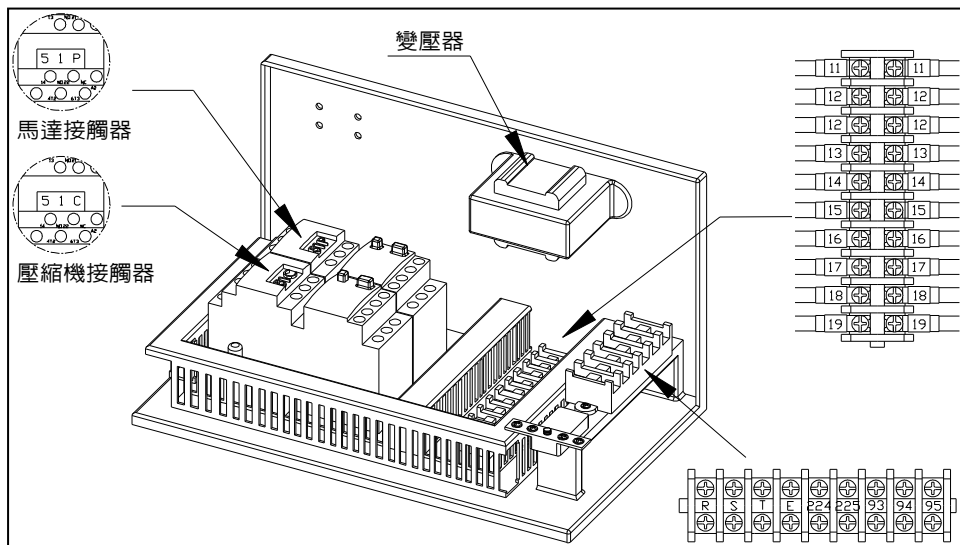

圖12



圖13

- (5) 當本機有配備油箱時，請檢查排液口、進口及出口是否有漏油現象？
- (6) 冷卻機與您所使用之工具機進出口之間是否有閥門未開啓？

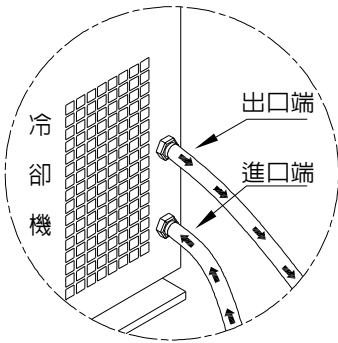
2. 操作程序及運轉中檢查：

當所有檢查都正確時，就可以進入操作程序，本公司冷卻機溫度設定可分為差溫型及定溫型，所謂差溫型也就是液溫追隨著室溫而改變，所謂定溫型也就是液溫追隨著設定溫度而改變。

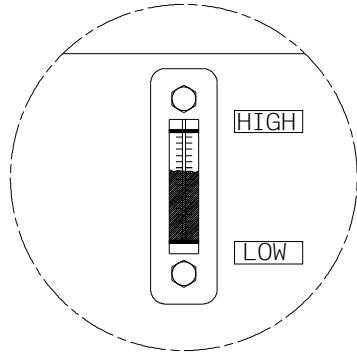
- (1) 按下電源開關。
- (2) 檢視溫度顯示器是否正常出現數據。
- (3) 當本機配備有排氣孔時，請檢視是否有正確排氣，排完氣，請務必關緊排氣孔閥門。
- (4) 請檢視有配備馬達之冷卻機，馬達轉向是否正確，或者有無異常聲音。
- (5) 使用設定鍵，調整到所需求溫度（有關溫度設定請詳閱 3. 控制器介紹）。

3. 控制器介紹

本冷卻機所使用的操作方式分為單螢幕電子顯示溫度控制(即SA系列小基板)與螢幕電子顯示溫度控制(即S系列大基板)二種。分別說明如下：

(1) 單螢幕電子顯示溫度控制(即SA系列小基板)：

● 控制面板外觀，如(圖15)所示：

● 控制面板說明：

- ⊕ 電源開關：冷卻機啓停開關、觸控型開關。



圖15

設定鍵

ROOM SET 室溫切換開關：若按此鍵可顯示室溫，放開5秒後即顯示液溫。

⏪ SET TEMP 溫度設定開關：按 ⏪ 鍵，螢幕會閃爍，便進入溫度設定模式。

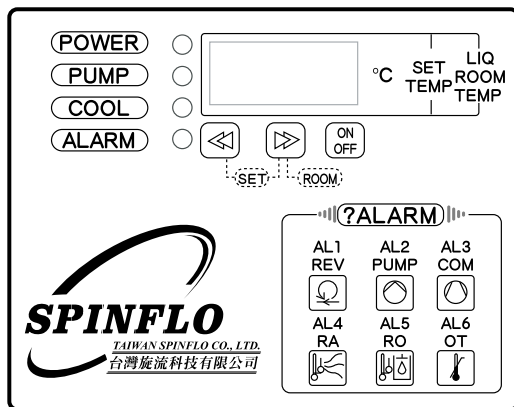
⏩：高溫設定鍵 ⏪：低溫設定鍵

● 運轉指示燈：

- POWER 綠色/電源指示燈：總電源燈，燈亮起時，顯示冷卻機已通電。
- PUMP 綠色/泵浦指示燈：燈亮起時，表示泵浦正常運轉中。
- COOL 綠色/冷卻指示燈：燈亮起時，表示壓縮機正常運轉中。
- ALARM 紅色/故障警示燈：燈亮起時，表示冷卻機系統出現異常。

● 操作說明：

請依您所選購之機型控制。

◎ 小型控制器的定溫式控制原理及方式：

螢幕常顯示值為目前液溫值，而當您按 ⏪ 鍵，螢幕會閃爍，隨即便進入溫度設定模式；使用 ⏪ ⏩ 便可調整您所要設定的溫度，設定完成後約3秒，螢幕會自動切換回目前液溫值，而此時液溫就會維持在您所設定的溫度值。

◎ 小型控制器的差溫式控制原理及方式：

螢幕常顯示值為液溫值，而按住 ⏩ 會顯示室溫值，而按 ⏪ 鍵螢幕會閃爍，此時便進入差溫設定模式，便可使用 ⏪ ⏩ 鍵設定您所需求的差溫值，設定完成後約3秒螢幕會自動切換回液溫值，此時液溫會隨著室溫做差溫變化設定。



圖16

(2) 雙螢幕電子顯示溫度控制(即S系列大基板)：

- 控制面板外觀，如(圖16)所示：
- 控制面板說明： 電源開關：冷卻機啓停開關、觸控型開關。

設定鍵 LIQ ROOM SET 室溫切換開關：若按此鍵可顯示室溫，放開5秒後即顯示液溫。

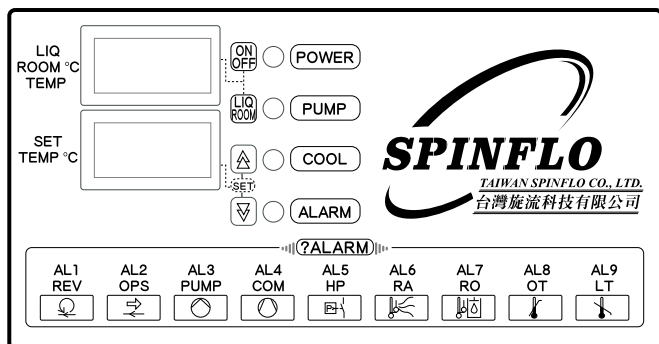
SET TEMP 溫度設定開關：：溫度設定上鍵
 SET TEMP 溫度設定開關：：溫度設定下鍵

顯示器

LIQ / ROOM / TEMP 顯示螢幕：顯示目前液溫或室溫，故障時會顯示AL-1(或-2到-9, 分別代表故障訊息)

SET / TEMP 顯示螢幕：顯示欲設定之溫度或差溫型欲設定之設定溫差值。

● 運轉指示燈：

- POWER 綠色/電源指示燈：總電源燈,燈亮起時，顯示冷卻機已通電。
- PUMP 綠色/泵浦指示燈：燈亮起時，表示泵浦正常運轉中。
- COOL 綠色/冷卻指示燈：燈亮起時，表示壓縮機正常運轉中。
- ALARM 紅色/故障警示燈：燈亮起時，表示冷卻機系統出現異常。

● 操作說明：

請依您所選購之機型控制。

◎大型控制器的定溫式控制原理及方式：

LIQ/ROOM/TEMP 顯示螢幕：會顯示目前液體的溫度，而按 會顯示目前的室溫，而 SET/TEMP 顯示螢幕：顯示你欲設定之溫度，此時使用 便可設定你欲達到的溫度值，而壓縮機會隨著你所設定之溫度啟動和停止(而其啟動和停止的溫差值為本公司標準設定值，若有特殊需求請與本公司連絡)。

如：假設目前的LIQ/ROOM/TEMP顯示螢幕會顯示目前液體溫度為30°C，而希望液溫達到25°C，於是可以使用 將SET/TEMP顯示螢幕溫度設定值調整為25，而此時溫度將達到你所需溫度25°C，並維持在25°C上下。

◎大型控制器的差溫式控制原理及方式：

LIQ/ROOM/TEMP顯示螢幕會顯示目前液體的溫度，而按 會顯示目前的室溫，而 SET/TEMP顯示螢幕會顯示你目前希望液溫追隨室溫的溫差值，此時使用 便可設定你需求的溫差值(加上本公司之內定溫差值)，而壓縮機並隨著你所設定之溫差啟動和停止。

四、保養規範

為維持冷卻機之冷卻效率並延長使用壽命，冷卻機應確實做好定期保養，而任何清潔與保養請勿在冷卻機運轉下進行。詳細事項請參考如下資料：

1. 如果必須拆到外板金，進行內部保養時，請務必將冷卻機關閉，以免碰觸到熱源或者是碰觸到風扇，造成傷害。
2. 機體外型保養，請使用中性清洗劑或肥皂清洗表面污垢，切勿使用酸性溶劑以免腐蝕表面烤漆部份，清洗時嚴禁將水噴掃到電控部份，以免造成電器受損。
3. 定期作過濾網保養，每週定期使用噴槍清掃塵埃，若過濾網有油污不易噴清，可使用清洗劑清洗，如(圖17)所示。
4. 定期使用壓縮空氣清除冷凝氣的灰塵，空氣噴槍須與散熱鰭片成垂直方向上下噴吹。
5. 濕氣會造成油箱底部有水分凝結，使用者可視冷卻機安裝場所濕氣含量，定期由油箱底部排液口排除水分。
6. 若您在進口或出口位置有加裝過濾器時，請定期更換或清洗濾心，如(圖18)所示。



圖17



圖18

五、故障排除

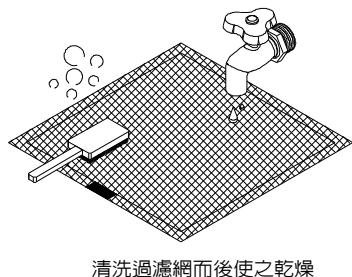
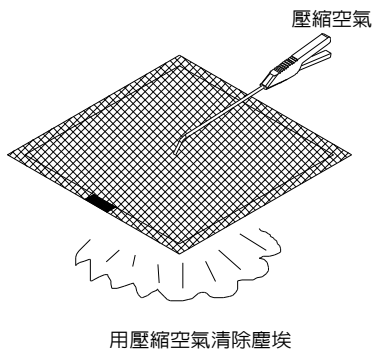
本機雖經由嚴格、完善的品質控管下才出廠，但萬一發生故障，請參考以下資料尋求適當的處理對策，若仍然無法順利運轉，請查看冷卻機以下二項規格後盡快向本公司營業處連絡。

- 1.機型、製造機號(均在冷卻機規格銘版)。
- 2.機械面板故障燈號。

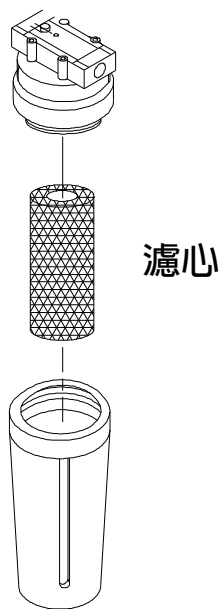
表二為各故障訊號的快速查詢表單

基板型式	異常訊號		快速查詢頁數 單節
	顯示符號	異常原因	
小基板 (SA系列)	AL.1	REV欠相，逆相	第十五頁 (5-1-1)
	AL.2	泵浦馬達異常	第十六頁 (5-1-2)
	AL.3	壓縮機馬達異常 (OPS.HP.COMP)	第十七頁 (5-1-3)
	AL.4	RA室溫感溫棒異常	第十九頁 (5-1-4)
	AL.5	RO液溫感溫棒異常	第二十頁 (5-1-5)
	AL.6	OT液溫過高	第二十頁 (5-1-6)
大基板 (S系列)	AL.1	REV欠相，逆相	第二十一頁 (5-2-1)
	AL.2	OPS液壓迴路異常	第二十二頁 (5-2-2)
	AL.3	泵浦馬達異常	第二十三頁 (5-2-3)
	AL.4	壓縮機馬達異常	第二十三頁 (5-2-4)
	AL.5	HP冷煤壓力異常	第二十四頁 (5-2-5)
	AL.6	RA室溫感溫棒異常	第二十四頁 (5-2-6)
	AL.7	RO液溫感溫棒異常	第二十五頁 (5-2-7)
	AL.8	OT液溫過高	第二十五頁 (5-2-8)
	AL.9	LT液溫過低	第二十五頁 (5-2-9)

表二

目前故障排除必須拆除到上蓋及開啓配電箱方式，目前開啓配電箱大致上可分為三種方式:(1)門扣型，如(圖19)所示。(2)拆前版型，如(圖20)所示。(3)掀上蓋型，如(圖21)所示。電器箱位置皆有三角形閃電貼紙標示之。

註：在從事冷卻機的檢查和保養時，為維護安全起見，必須先將電源總開關切斷。

門扣型(圖19)

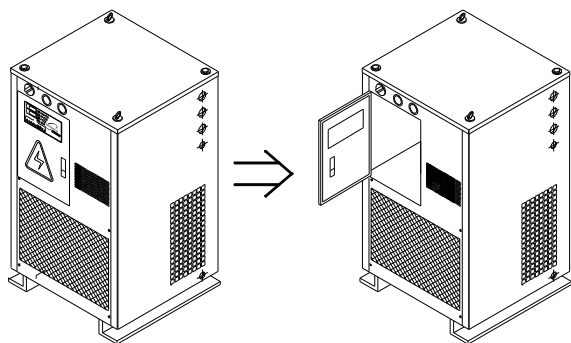

拆前版型(圖20)

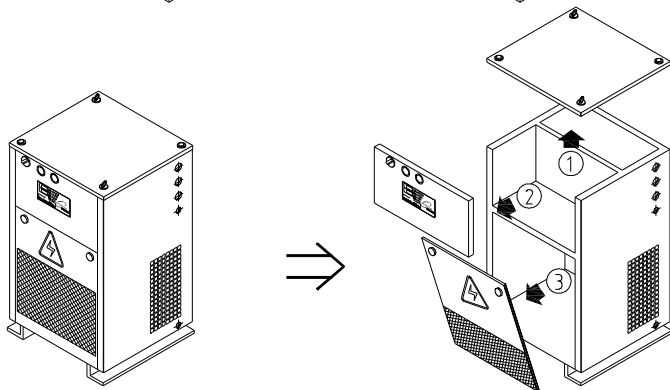

掀上蓋型(圖21)

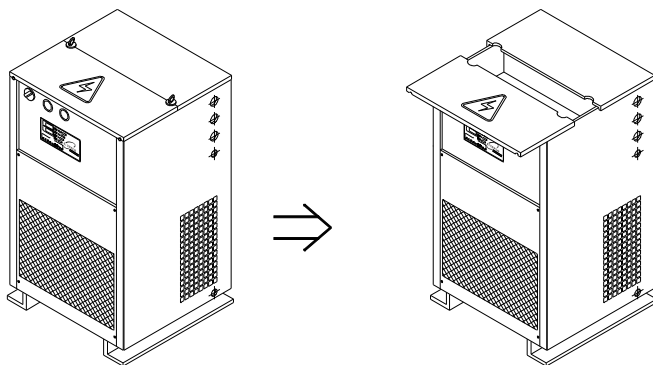

5-1.單螢幕電子顯示溫度控制(即小基板，SA系列)：

(1) 有顯示異常訊號(即ALARM紅燈顯示)：

5-1-1 AL-1 REV 欠相、逆相：表示三相電源欠相或逆相異常。

可能原因	故障排除
三相電源相序錯誤。	將電源線其中兩條R、T對調即可。
三相壓降、差值超過。	請使用者做好穩壓工作或裝置穩壓器。
基板後方3P排線連接頭是否鬆脫。	請先關掉電源後重新接好。
配電盤內RST螺絲是否鬆脫。	請用十字起子鎖緊。
基板故障。	更換基板。

檢查方式及排除方法

- 1、請參考(圖19.20.21)，找出適當的方式，開啓配電箱，找出配電盤中編號R、T二種電線，利用十字起子將該兩條電線互換，如(圖22)所示。
- 2、利用三用電表檢查電流是否穩定？電壓是否足夠、平衡？如(圖23)所示。



圖22



圖23

5-1-2 AL-2 PUMP 馬達泵浦：泵浦馬達異常。

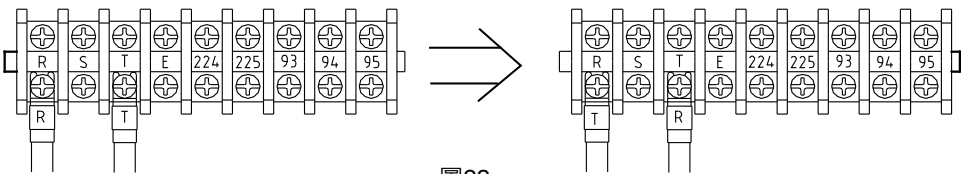
請先確認引起的原因，如果重新開機即馬上跳脫，引起原因為馬達電流過載。

可能原因	故障排除
積熱電驛跳脫。	將保護器重新復歸並將電流值提高。
吸油管阻塞。	清理油路、更換濾油器。
馬達故障。	更換馬達。
負載側接觸不良。	請檢查是否有接觸不良之處。
出油口有阻塞、折壓到。	請改善油壓管路。
過載保護器故障。	更換過載保護器。

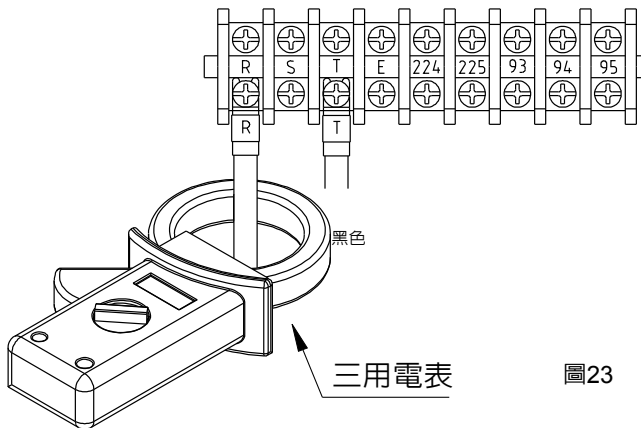
檢查方式及排除方法

1、當確定為馬達過電流所產生的時候，請參考(圖19.20.21)，找出適當的方式，開啓配電箱，找出編號51P的電子接觸器，按下"RESET"後，冷卻機請重新開機，如(圖24)所示。

註：相關位置請參考(圖11) 配電箱內各電子零件的相對位置參考圖。



圖11



圖24

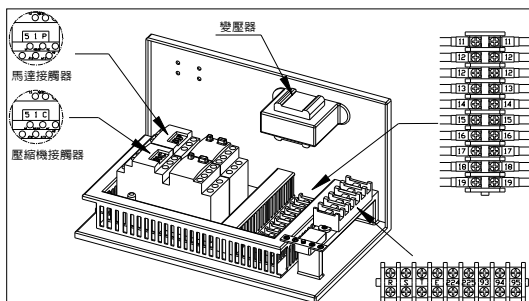

門扣型(圖19)

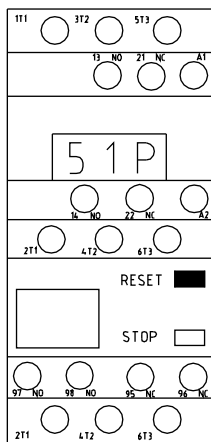
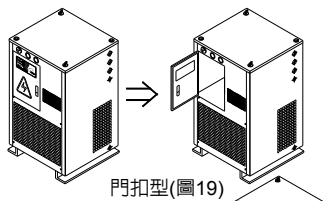
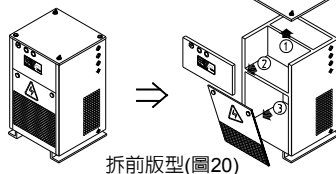

拆前板型(圖20)

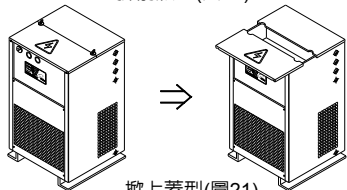

掀上蓋型(圖21)

5-1-3 AL-3 COMP(Compressor) 壓縮機馬達及OPS(Oil Pressure Switch)油壓開關、HP(High Pressure)冷媒高低壓開關：壓縮機馬達異常、液壓迴路異常、冷媒壓力異常，如果約開機六秒後才跳脫引起原因為油壓開關。

可能原因	故障排除
積熱電驛跳脫。	將保護器重新復歸並將電流值提高。
壓縮機故障。	更換壓縮機。
冷凝器太髒。	使用壓縮空氣將油污、粉塵清乾淨再開機。
空氣過濾網太髒。	清洗過濾網。
冷卻風扇沒運轉或葉片脫落。	鎖緊葉片或更換風扇馬達。
冷媒壓力開關故障。	更換冷媒壓力開關。
油壓力開關故障。	調整油壓開關(OPS)之DIFF於0.3kgf/cm ² 範圍於0.5~0.8cmHg。
冷卻機周圍散熱空間不足造成高壓跳脫	請將冷卻機移至散熱空間良好之場所(離壁50cm以上)
進口端阻塞、鬆動。	檢查、清理油路、鎖緊油管。
進出口反接。	將進出口接正確。
幫浦馬達反接。	將積熱電驛(51 P)之紅、白線對調。
馬達軸心損耗無法帶動幫浦而空轉。	更換油幫浦。
油路循環潤滑油不夠。	將冷卻油箱或機械主軸頭補加適當循環油。
入口處油管鬆脫。	重新將油管鎖緊。
過濾器阻塞。	更換新過濾器。
積熱電驛跳脫。	將保護器重新復歸並將電流值提高。
吸油管阻塞。	清理油路、更換濾油器。
馬達故障。	更換馬達。
過載保護器故障。	更換過載保護器。

檢查方式及排除方法

- 請參考(圖19.20.21)，找出適當的方式，開啓配電箱，找出編號51C的繼電器，按下"RESET"，如(圖25)所示。
 - 掀後蓋，找尋冷媒高低壓開關，按下"RESET"，如(圖26)所示。
 - 當確定是油壓開關所產生的故障訊號，請依下列動作檢查：
 - 檢查進口端是否有迴油流入，如果沒有AL-3為正常現象。
 - 如果沒有，請將配電箱內編號12.13號線路短接，如(圖27)所示，如仍然有AL-3產生，請通知原廠，進行更換基板。
 - 若解決AL-3時，確定油壓開關所產生，請參考(圖28)，開啓上蓋，進行調整油壓開關。
 - 利用十字起子調整壓力開關上方之壓力扭，以游標下方為基準，使其壓力接近0，但不可低於0，以免產生負壓，如(圖29)所示。
- 註：相關位置請參考(圖11) 配電箱內各電子零件的相對位置參考圖。



圖25



圖26

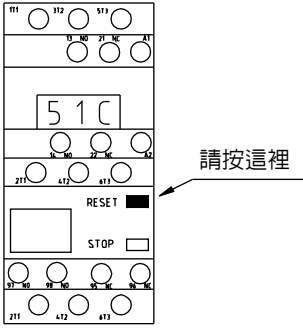

圖27

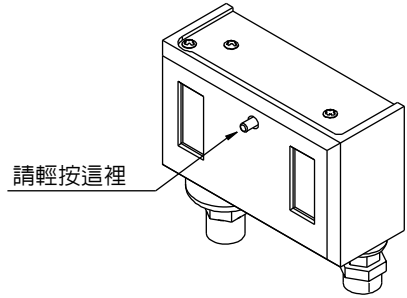

圖28

請以游標下方為基準

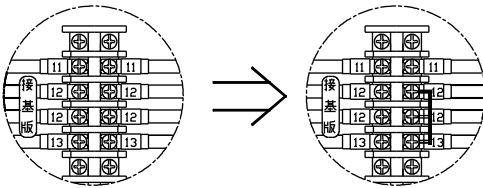

請用十字起子調整這類

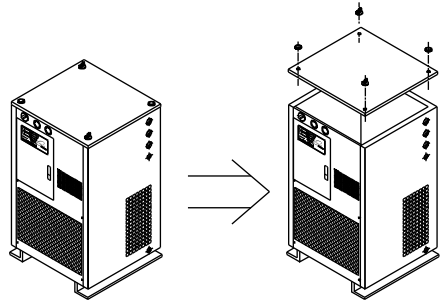
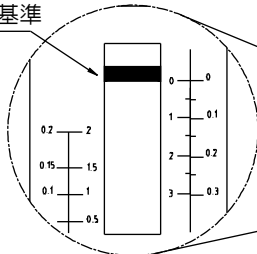

圖29

5-1-4 AL-4 RA(Room Temperature) 室溫探測棒：室溫感溫棒異常。

可能原因	故障排除
室溫感測棒故障。	更換RA室溫感測棒。
基板上的sensor線鬆脫。	請使用者重新鎖緊。
基板故障。	請更換基板。

檢查方式及排除方法

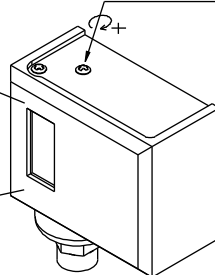
- 當AL-4時，可以將編號20.21及22.23二組訊號線互調，如圖(30-1.30-2)所示，當冷卻機仍然顯示AL-4時，請通知原廠，進行更換基板。
- 當互調之後，冷卻機卻出現AL-5訊號時，確定為室溫感測棒故障，請通知原廠，進行更換室溫感測棒。

註：20.21為液溫感測棒的線號，22.23為室溫感測棒的線號。



圖30-1



圖30-2

故障排除

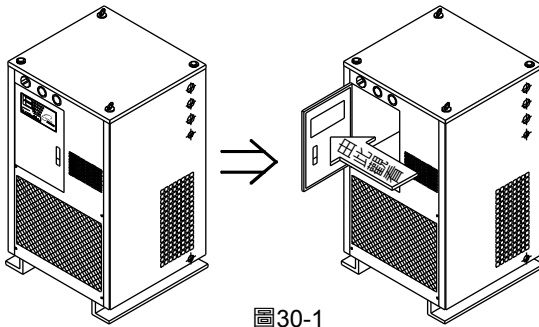
5-1-5 AL-5 RO(Liquid Temperature) 液溫探測棒：液溫感溫棒異常。

可能原因	故障排除
液溫感測棒故障。	更換RO液溫感測棒。
基板上的sensor線鬆脫。	請使用者重新鎖緊。
基板故障。	更換基板。

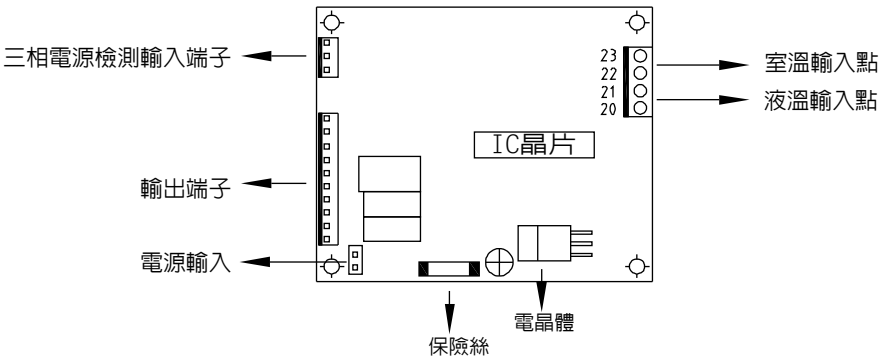
檢查方式及排除方法

- 1、當AL-5時，可以將編號20.21及22.23二組訊號線互調，如(圖30-1.30-2)所示，當冷卻機仍然顯示AL-5時，請通知原廠，進行更換基板。
 - 2、當互調之後，冷卻機卻出現AL-4訊號時，確定為液溫感測棒故障，請通知原廠，進行更換液溫感測棒。
- 註：20.21為液溫感測棒的線號，22.23為室溫感測棒的線號。



圖30-1



圖30-2

5-1-6 AL-6 OT(Over Temperature) 液溫過高：液溫過高。

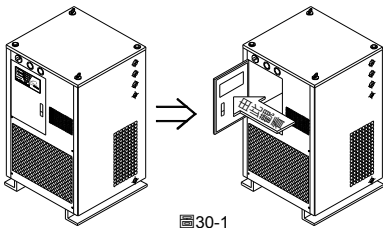
可能原因	故障排除
液溫過高。	先停機待液溫降至容許範圍再開機。
冷卻系統不冷，檢查冷卻冷媒是否不足。	更換溫度感溫器檢漏後補充冷媒。
液溫感測棒故障。	更換液溫感測棒。
壓縮機無運轉。	檢查壓縮機控制迴路。
壓縮機電磁接觸器故障。	更換電磁接觸器。
壓縮機過載保護器故障。	更換過載保護器。
冷媒量不足。	請檢查冷媒壓力值是否足夠、電流值是否符合銘板上數值。

檢查方式及排除方法

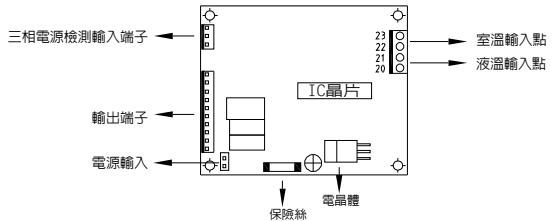
請參考第20頁5-1-5AL-5，液溫感測棒異常處理方式排除。

(2) 未顯示異常訊號： ■ POWER 指示燈不亮

可能原因	故障排除
基板入電電源線脫落	重新將基板後方輸入電源線插好。
變壓器燒燬。	更新變壓器。
基板保險絲斷路。	更新保險絲。
指示燈燒燬。	更新控制基板。
端子台224.225未短線。	請裝上短路片或與工作機台連接。

檢查方式及排除方法

註：電源輸入位置、保險絲位置，請參考第19頁(圖30-1.30-2)。



圖30-1



圖30-2

5-2. 雙螢幕電子顯示溫度控制(即大基板，S系列)：

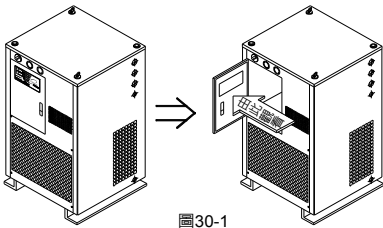
(1) 有顯示異常訊號(即ALARM紅燈顯示)：

5-2-1 AL-1 REV 欠相、逆相：表示三相電源欠相或逆相異常

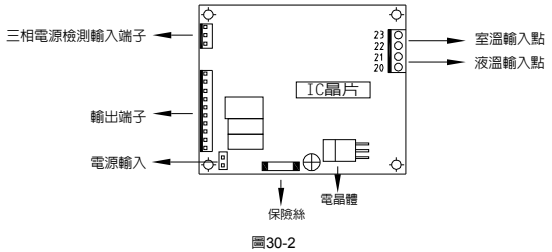
可能原因	故障排除
三相電源相序錯誤。	將電源線其中兩條R、T對調即可。
三相壓降、差值超過。	請使用者做好穩壓工作或裝置穩壓器。
基板後方3P排線連接頭是否鬆脫。	請先關掉電源後重新接好。
配電盤內RST螺絲是否鬆脫。	請用十字起子鎖緊。
基板故障。	更換基板。

檢查方式及排除方法

請參考第15頁，5-1-1 AL-1 REV 欠相、逆相異常排除方式處理。

5-2-2 AL-2 OPS(Oil Pressure Switch) 液壓開關：液壓迴路異常。

可能原因	故障排除
進口端阻塞、鬆動。	檢查、清理油路、鎖緊油管。
進出口反接。	將進出口接正確。
幫浦馬達反接。	將積熱電驛(51 P)之紅、白線對調，並檢視轉向是否正確。
馬達軸心損耗無法帶動幫浦而空轉。	更換油幫浦。
油路循環潤滑油不夠。	將冷卻油箱或機械主軸頭補加適當循環油。
入口處油管鬆脫。	重新將油管鎖緊。
過濾器阻塞。	更換新過濾器。
油壓壓力開關故障。	調整油壓開關(OPS)之DIFF於0.3kgf/cm ² 範圍於0.5~0.8cmHg。
油壓管內有空氣。	於幫浦排氣孔先做排氣動作。
馬達故障。	更換馬達。

檢查方式及排除方法

- 1、確認冷卻機進口端及出口端相對位置，如(圖31)所示。
- 2、檢查進口端是否有迴油，如(圖32)所示。
- 3、當確定是油壓開關所產生的故障訊號，請依下列動作檢查：
 - A. 檢查進口端是否有迴油流入，如果沒有AL-2為正常現象。
 - B. 如果沒有，請將配電箱內編號12.13號線路短接，如(圖27)所示，如仍然有AL-2產生，請通知原廠，進行更換基板。
 - C. 若解決AL-2時，確定油壓開關所產生，請參考(圖28)，開啓上蓋，進行調整油壓開關。
- 4、利用十字起子調整壓力開關上方之壓力扭，以指標下方為基準，使其壓力接近0，但不可低於0，以免產生過低壓，造成不可預期的故障，如(圖33)所示。



圖27



圖28

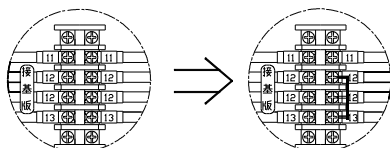
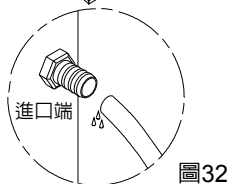
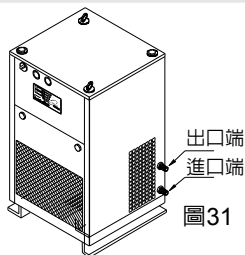

圖33

5-2-3 AL-3 PUMP 馬達泵浦：泵浦馬達異常。

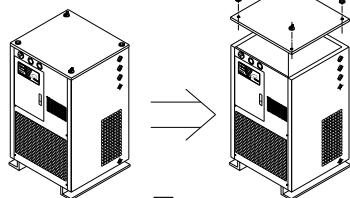
可能原因	故障排除
積熱電驛跳脫。	將保護器重新復歸並將電流值提高。
吸油管阻塞。	清理油路、更換濾油器。
馬達故障。	更換馬達。
負載側接觸不良。	請檢查是否有接觸不良之處。
出油口有阻塞、折壓到。	請改善油壓管路。
過載保護器故障。	更換過載保護器。

檢查方式及排除方法

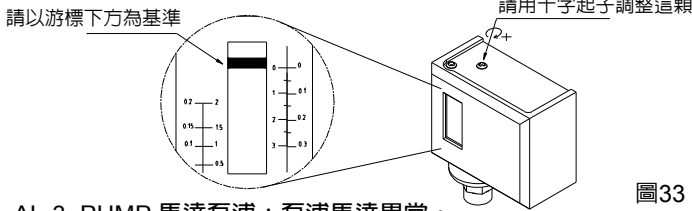
- 請參考(圖19.20.21)，找出適當的方式，開啓配電箱，如(圖26)所示，找出編號51P的電子接觸器，按下"RESET"，如(圖25)所示。



圖25



圖26

5-2-4 AL-4 COMP(Compressor) 壓縮機馬達：壓縮機馬達異常。

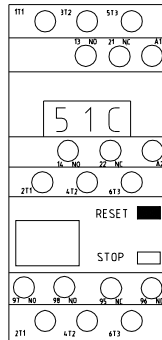
可能原因	故障排除
積熱電驛跳脫。	將保護器重新復歸並將電流值提高。
壓縮機故障。	更換壓縮機。
負載側接觸不良。	請檢查是否有接觸不良之處。
電源電壓非適用電壓或不穩定的電壓。	請改善電源電壓及電壓穩定性。
過載保護器故障。	更換過載保護器。

檢查方式及排除方法

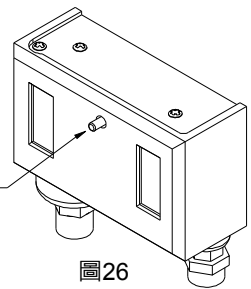
- 請參考(14頁;圖19.20.21)，找出適當的方式，開啓配電箱，找出編號51C的電子接觸器，按下"RESET"，如(圖25)所示。

故障排除

5-2-5 AL-5 HP(High Pressure) 冷媒高低壓開關：冷媒壓力異常。

可能原因	故障排除
冷凝器太髒。	使用壓縮空氣將油污、粉塵清乾淨再開機。
空氣過濾網太髒。	清洗過濾網。
冷卻風扇沒運轉或葉片脫落。	鎖緊葉片或更換風扇馬達。
冷媒壓力開關故障。	更換冷媒壓力開關。
冷卻機周圍散熱空間不足造成高壓跳脫。	請冷卻機移至散熱空間良好之場所(離壁50cm以上)。
系統內冷媒不足。	請通知原廠處理。

請輕按這裡



圖26

檢查方式及排除方法

1、掀後蓋，找尋冷媒高低壓開關，按下"RESET"，如(圖26)所示。

5-2-6 AL-6 RA(Room Temperature) 室溫探測棒：室溫感測棒異常。

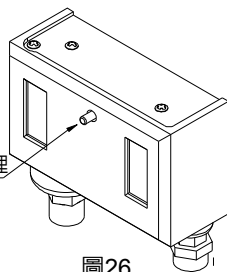
可能原因	故障排除
室溫感測棒故障。	更換RO液溫感測棒。
基板上的sensor線鬆脫。	請使用者重新鎖緊。
基板故障。	更換基板。

檢查方式及排除方法

請參考第19頁，室溫感測棒異常排除方法。



圖34-1



圖34-2

5-2-7 AL-7 RO(Liquid Temperature) 液溫探測棒：液溫感測棒異常。

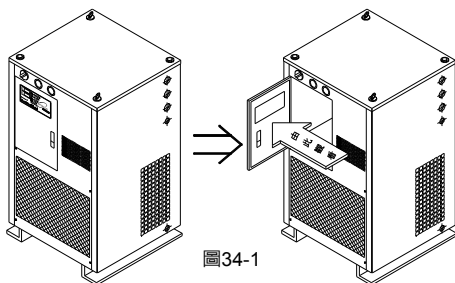
可能原因	故障排除
液溫感測棒故障。	更換RO液溫感測棒。
基板上的sensor線鬆脫。	請使用者重新鎖緊。
基板故障。	更換基板。

檢查方式及排除方法

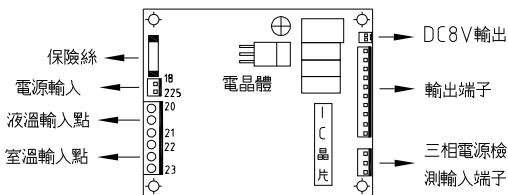
請參考第20頁5-1-5AL-5，液溫感測棒異常排除方式處理。

5-2-8 AL-8 OT(Over Temperature) 液溫過高：液溫過高。

可能原因	故障排除
液溫過高。	先停機待液溫回復至容許範圍再開機。
冷卻系統不冷，檢查冷卻冷媒是否不足。	更換溫度感溫器檢漏後補充冷媒。
液溫感測棒故障。	更換液溫感測棒。
壓縮機無運轉。	檢查壓縮機控制迴路。
壓縮機電磁接觸器故障。	更換電磁接觸器。
壓縮機過載保護器故障。	更換過載保護器。
冷媒量不足。	請檢查冷媒壓力值是否足夠、電流值是否符合銘板上數值。

5-2-9 AL-9 LT(Low Temperature) 液溫過低：液溫過低。

可能原因	故障排除
液溫過低。	先停機待液溫回復至容許範圍再開機。
液溫感測棒故障。	更換液溫感測棒。
壓縮機控制迴路異常。	檢查壓縮機控制迴路。
壓縮機電磁接觸器故障。	更換電磁接觸器。
壓縮機過載保護器故障。	更換過載保護器。

(2) 未顯示異常訊號：■ POWER 指示燈不亮。

可能原因	故障排除
18、225電源線脫落。	重新將18、225電源輸入線插好。
變壓器燒燬。	更新變壓器。
基板保險絲斷路。	更新保險絲。
指示燈燒燬。	更新溫度基板。
端子台224.225未短線。	請裝上短路片或與工作機台連接。

檢查方式及排除方法

註：電源輸入位置、保險絲位置，請參考第24頁(圖34-1.34-2)。

I	General.....	27
II	Installation.....	27
	1.Transportation.....	27
	2.Installation Conditions and Environmental Limitation.....	28
	3. Choosing oil for oil cooler.....	29
	4. Piping system.....	29
	5. Electrical wiring.....	30
III	Operation.....	35
	1. Inspection and preparation before operation.....	35
	2. Operation process and the inspection	35
	3. Temperature controller introduction.....	36
IV	Maintenance.....	38
V	Troubleshooting.....	39
	5-1. Single Temperature Display controller (SA series).....	41
	5-1-1 AL-1 means Input voltage phase lack or phase reverse.....	41
	5-1-2 AL-2 means pump motor abnormal.....	42
	5-1-3 AL-3 COMP (Compressor) and OPS (Oil Pressure Switch) switch: Compressor Is abnormal or oil pressure Is abnormal.	43
	5-1-4 AL-4 RA (Room Temperature): Room temperature sensor abnormal.	45
	5-1-5 AL-5 RO(Liquid Temperature) Coolant temperature sensor abnormal.....	46
	5-1-6 AL-6 OT(Over Temperature) Coolant temperature is too high.....	46
	5-2. Two-temperature display controller (S series)	47
	5-2-1 AL-1 means input voltage phase lack or phase reverse.....	47
	5-2-2 AL-2 OPS(Oil Pressure Switch) : Coolant pressure abnormal.....	48
	5-2-3 AL-3 PUMP motor : Pump motor abnormal.....	49
	5-2-4 AL-4 COMP(Compressor) : compressor abnormal.....	49
	5-2-5 AL-5 HP (High Pressure) : refrigerant pressure abnormal.....	50
	5-2-6 AL-6 RA(Room Temperature) :sensor abnormal.....	50
	5-2-7 AL-7 RO(Liquid Temperature) : Gcoolant temperature sensor abnormal.....	50
	5-2-8 AL-8 OT(Over Temperature): coolant temperature Is too high.....	51
	5-2-9 AL-9 LT (Low Temperature): coolant temperature is too low.....	51
	Warranty Card	53

I \ General

Thanks for choosing TAIWAN SPINFLO products. TAIWAN SPINFLO cooler has two models, PS (without reservoir) model and PTS(with reservoir) model. PS model is suitable for cooling gearbox and coolant tank of the machine tools. PTS is specially designed for cooling spindle and slides.

TAIWAN SPINFLO cooler is widely used for cooling CNC grinding machine, CNC machine center, CNC lathe, CNC engraving machine and CNC press machine...etc. TAIWAN SPINFLO cooler can keep machine spindle system at constant temperature condition to ensure the machining precision for long running time.

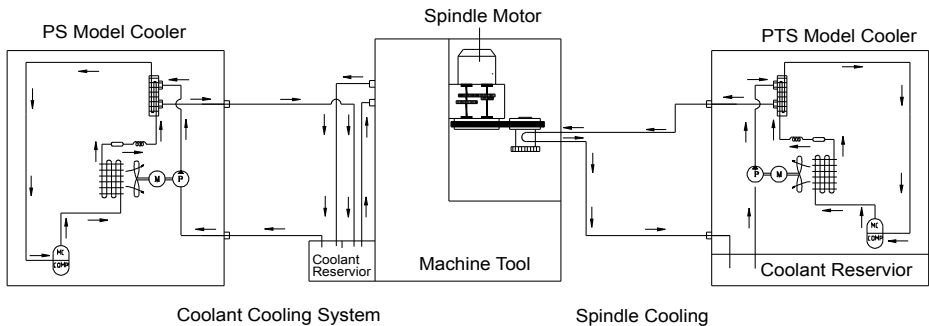

Figure 1

II \ Installation

1. Transportation

- (1) During the transportation and installation, keep the cooler position vertically all the time. The max. slant angle can not over 45 degree.(See Figure 2.)
- (2) Disconnect power line and vent the coolant in the cooler before move it.
- (3) If using forklift to move the cooler, keep the cooler lower than 20 cm height from the ground all the time. (See Figure 3)

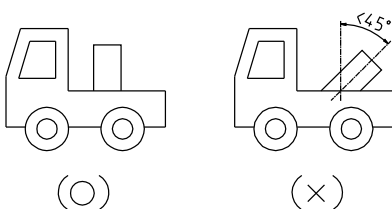

Figure 2

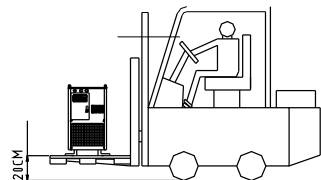

Figure 3

(4) If using crane to move the cooler, please check following condition:

Check the cooler weight (See the plate at the cooler left side) to choose proper crane and rope. (See Figure 4)

Keep the cooler balance and prevent crash to any thing when moving.

People have to keep a safety distance from cooler and crane when moving.

Hz	220 V	0.5
Hz	V	A
REFRIGERANT	R-22	
WEIGHT	100 KGS	
DELIVERY DATE	2006/04/12	
AN SPINFLO CO.,LTD.		
886-4-2339-9768		

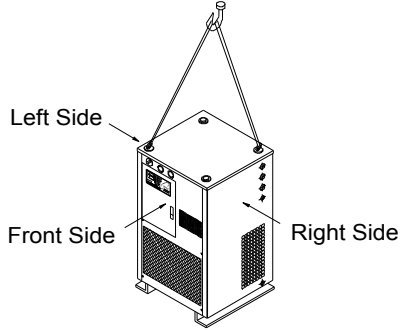

Figure 4

2. Installation Conditions and Environmental Limitation

- (1) The cooling temperature for cooler is between 25~35°C. And the room temperature should be 5~40°C to ensure cooler's cooling capacity.
- (2) Install the cooler at a place has good ventilation and far away from dusty area.
- (3) Install the cooler on the leveled ground. Slant installation is strictly prohibited.
- (4) Install the cooler far away from water spraying area.
- (5) Do not store any goods around cooler; it might block the win flow through the condenser to make cooler overheat and shut down. (See Figure 5)
- (6) Do not install the cooler at outdoors. To prevent the cooler from direct sunlight, also away from heat source area.

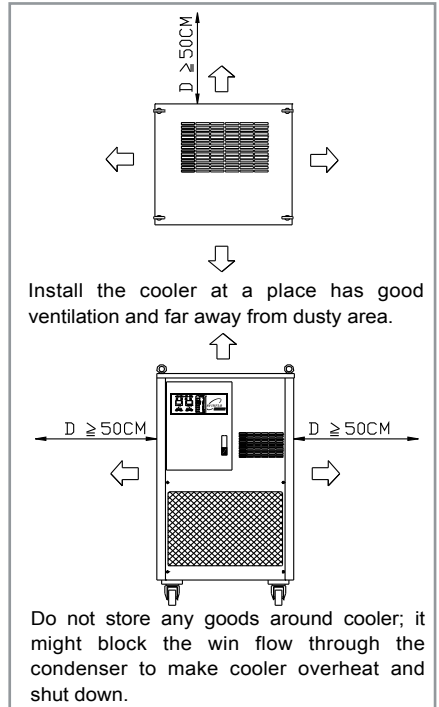

Figure 5

3. Choosing oil for oil cooler

- (1) Only use mineral base hydraulic and lubricant oil, strictly prohibited to use water, ethylene glycol...etc. (recommend to use #32 and #68 oil).
- (2) If the oil viscosity is too high or too low, it might make the pump defect or reduce its efficiency.
- (3) Oil viscosity-temperature as following for reference. (See Figure 6)

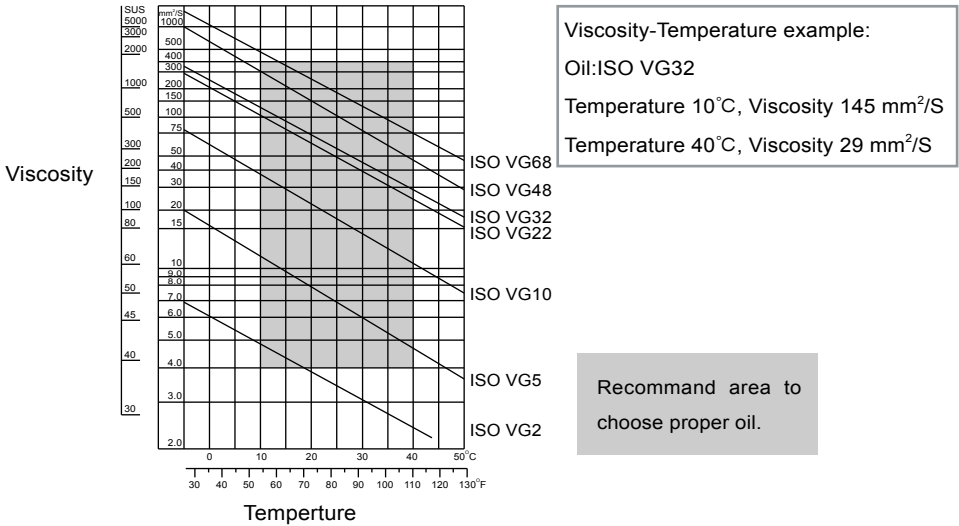

Figure 6

4. Piping system

- (1) Install the cooler as close as possible to the machine. Long piping will cause coolant pressure loss and reduce cooling capability.
- (2) If this cooler is oil cooler, the pipe connector material can be stainless steel, copper or steel.
- (3) Clean the pipe or connector by high pressure spraying air before installation.
- (4) Please using following chart to choose the pipe. Wrong pipe will reduce the cooling capability, and will make damage to the cooler for the long term. (See Chart 1)

NOTE: If the cooler is PS model, the pipe diameter is strictly prohibited to use smaller one.

Model NO.	40	60	80	100	120	180	240	360	480	600	900	1200
Inlet	1/2"	3/4"	3/4"	3/4"	3/4"	3/4"	3/4"	1"	1"	1"	1 1/4"	1 1/2"
Diameter	≥ 1/2"	≥ 3/4"	≥ 3/4"	≥ 3/4"	≥ 3/4"	≥ 3/4"	≥ 3/4"	≥ 1"	≥ 1"	≥ 1"	≥ 1 3/4"	≥ 1 1/2"

Chart 1

Installation

(5) Verify all the connectors' position of inlet, outlet, air vent, coolant vent, and refill. You can find all the labels on the cooler.

Note: The inlet and outlet position might be different due to different model, please check the labels on the cooler.

(6) Apply the seal tape on the pipe threads and tighten the connector under 150 kg/cm² to prevent leakage.

(7) Avoid bending the pipe, and don't use any additional valve if possible because it will cause pressure drop and reduce flow rate.

(8) Keep the pipe away from the electric wires to prevent circuit shot or people got electric shock.

5. Electrical wiring

(1) Carefully read the contents of the nameplate on the cooler, especially the voltage and model number before connecting the power.

(2) The color of grounding wire has to be yellow/green. And the grounding screws should have enough thread to fully contact with the metal guard.

(3) The input power contact, trouble shooting contact, remote control contact on the terminal block, please refer to figure 8.

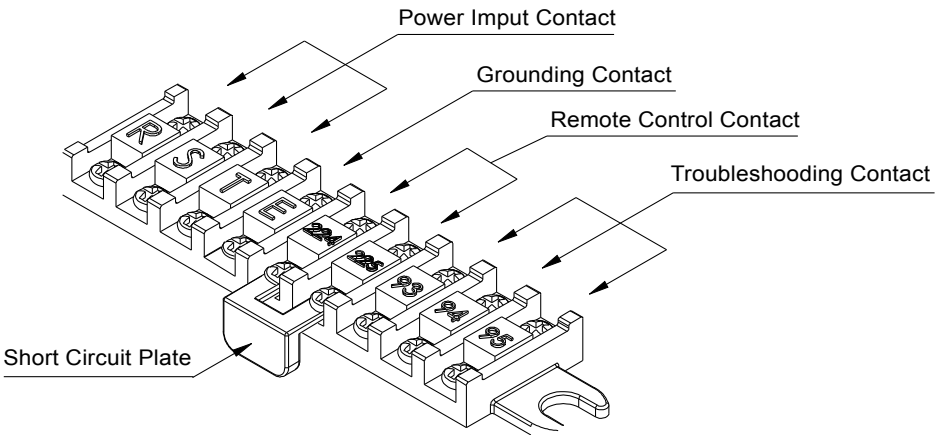

figure 8

- R/S/T (Power contact): When the cooler is power on, the controller has phase detect function. For example: If the input phase is reverse, the "AL-1 REV" alarm indicator will light. Please switch R and T power line to solve this problem.
- E is grounding contact.
- 93/94/95 is trouble-shooting contact: Our standard cooler uses 93 and 95 contacts only. When the cooler is under normal operation, 93/95 is b contact (close), and 93/94 is a contact (open). When ALARM happen, or the cooler is powered but not able to run, then 93/95 become a contact (open) and 93/94 become b contact (close).
Note: If your cooler didn't follow this way, please switch the wire on 94/95.)







Wire NO.	Normal		Alarm	
93.95				
93.94				

Chart 2

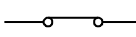
- 224/225 remote control contacts: these two contacts could connect to the CNC machine to control cooler to start or stop working. Normally 224/225 is shorted when cooler left the factory. If remote control function is needed, remove the short circuit plate on 224/225 and connect to your CNC machine as b contact.

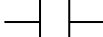
Installation

(4) Figure 9 and 10 are the standard circuit diagrams.

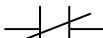
- ● MO338 single temperature display (SA series controller) circuit diagram, please refer to figure 9.

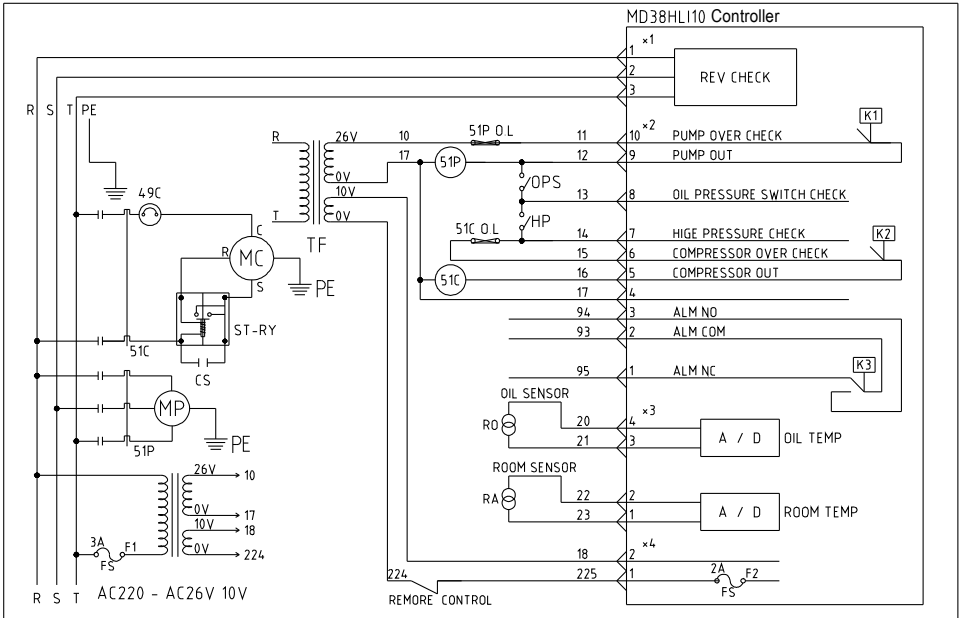

Figure 9.

51P Pump motor magnetic

51C O.L Compressor thermal overload relay

51C Compressor switch

51P O.L Pump motor thermal overload relay

RO Liquid temperature sensor

RA Room temperature sensor

MP Pump motor

MC Compressor motor

PE Ground wire

49C Compressor build in Th. OL. Ry

OPS Oil pressure switch

CS Starter capacitor

TC Running capacitor

FS Fuse

HP High pressure sw

ST-RY Starter Relay

TF Transformer

- MO332 two-temperature display (S series controller) circuit diagram, please refer to figure 10.

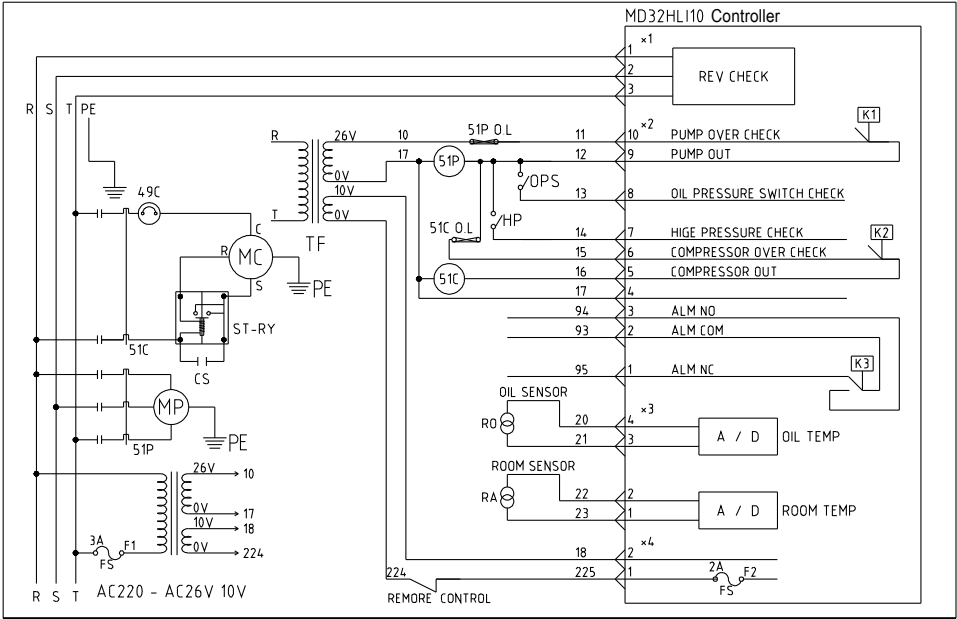

Figure 10.

- | | |
|--|---|
| 51P Pump motor magnetic switch | 49C Compressor build in Th. OL. Ry |
| 51C O.L Compressor over load protector | OPS Oil pressure switch |
| 51C Compressor magnetic switch | CS Starter capacitor |
| 51P O.L Pump motor thermal overload relay | TC Running capacitor |
| RO Liquid temperature sensor | FS Fuse |
| RA Room temperature sensor | HP High pressure sw |
| MP Pump motor | ST-RY Starter Relay |
| MC Compressor motor | TF Transformer |
| PE Ground wire | |

Installation

(5) Figure 11 is the electronic components position diagram.

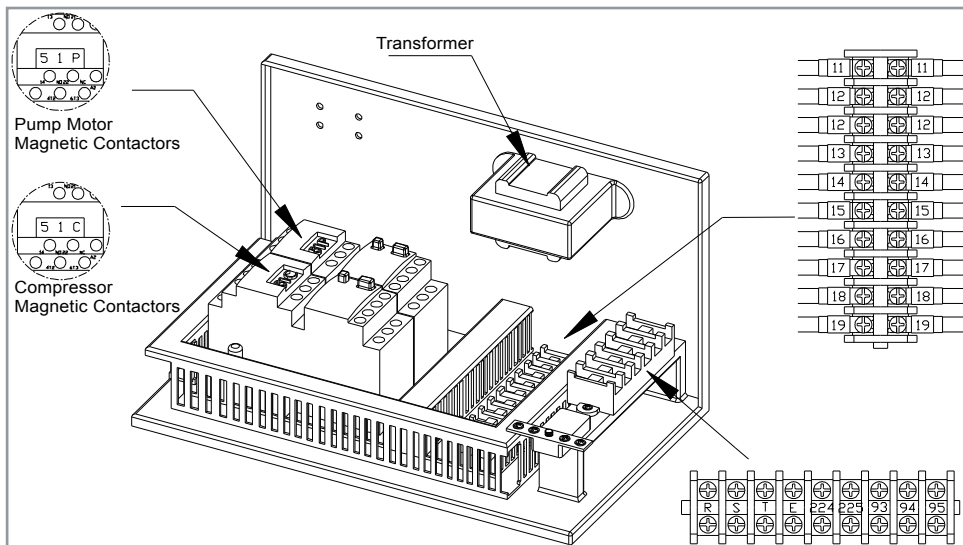

Figure 11

III \ Operation

1. Inspection and preparation before operation

- (1) After switch on the power, check to see if the POWER indicator on the panel lights?
- (2) If this cooler is equipped with High / Low refrigerant gauge, check to see if the low pressure is between 50 to 150 psi on the low pressure gauge.
- (3) Check if the oil or water pipes are correctly installed to the inlet and outlet on the cooler. (See Figure. 12)
- (4) If this cooler is equipped with water(oil) reservoir, check if the water(oil) level in the reservoir is normal (level should between High and Low lines). It is strictly prohibited to run the pump motor when there is no water(oil) in the reservoir. (See Figure 13)

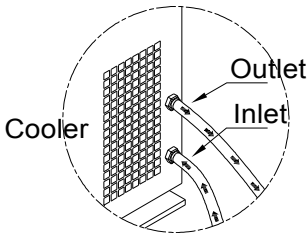

Figure. 12

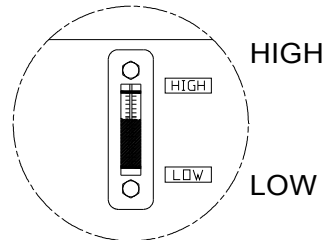

Figure. 13

- (5) If this cooler is equipped with water(oil) reservoir, check if there is any leakage at the inlet, outlet and vent valve.
- (6) Check if the all the valve that connects to machine center are properly set to "OPEN" position.

2. Operation process and the inspection

If all above preparation inspections show normal, then the cooler is ready to run. And the 1st step is to set up the coolant temperature. TAIWAN SPINFLO cooler temperature has two setting modes, "Differential Temperature Mode" and "Fix Temperature Mode". For differential temperature mode, the coolant temperature changes refer to the room temperature. For fix temperature mode, the coolant temperature will follow to the setting temperature. And setting process as following:

- (1) Press the power button.
- (2) Check if the temperature display shows number.
- (3) If this cooler is equipped with air vent, please check if the exhaust is normal. After the exhaust process is complete, please set the air vent valve to "CLOSE" position.
- (4) If this cooler is equipped with pump and motor, please check if the motor is rotating at right direction without any abnormal noise.
- (5) Press the temperature setting button to set up your working temperature. (Detail temperature setting process please refers to following controller introduction).



3. Temperature controller introduction

TAIWAN SPINFLO has two temperature controllers, one is single temperature display (SA Series) and the other is two-temperature display (S series). Detail introductions as following:

(1) Single temperature display (SA Series)

SA Series small control panel (See Figure 15)

Buttons:

- ON/OFF: Press this button to turn on or off the cooler.
- Temperature setting button: Press and hold  button, then display will blink and get into setting mode. Press  to increase temperature or press  to decrease temperature.

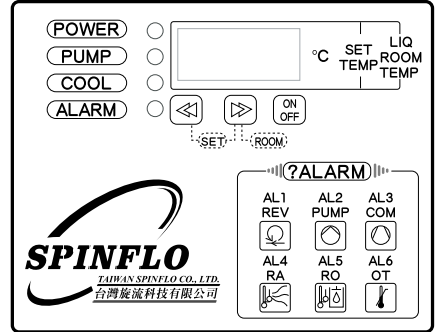









Figure 15

Indicators:

- POWER: Green indicator, lights mean power is on.
- PUMP: Green indicator, lights mean pump is running.
- COOL: Green indicator, lights mean compressor is running.
- ALARM: Red indicator, lights mean the cooler is abnormal.

Operation:

Please check this cooler is at "Differential Temperature Mode" and "Fix Temperature Mode", and follows different setting process.

- Fix Temperature Mode: The display always shows the coolant temperature. Press and hold  button, the display will blink and get into temperate setting mode. Press  or  button to increase or decrease setting temperature, after set to setting temperature, leave it alone for 3 seconds, then display will stop blinking, and setting is complete. The cooler will keep the coolant to the setting temperature.
- Differential Temperature Mode: The display always shows the coolant temperature. Press  button will show current room temperature. Press and hold  button, the display will blink and get into temperate setting mode. Press  or  button to increase or decrease the differential temperature, then leave it alone for 3 seconds, the display will stop blinking and setting is complete. The cooler will keep the coolant temperature to the setting differential temperature compare to the room temperature.

(2) Two temperature display (S Series)

S Series control panel (See Figure 16)

Figure 16

Buttons:

- ON/OFF: Press this button to turn on or off the cooler.
- LIQ. ROOM : Always show coolant temperature, and press and hold this button to show room temperature. It will come back to coolant temperature after 5 seconds after the button is released.

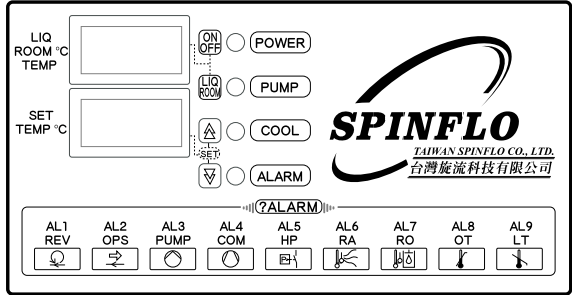

- Temperature setting button: Press and hold **SET** button, then display will blink and get into setting mode. Press **▲** to increase temperature or press **▼** to decrease temperature.

Displays:

- LIQ/ROOM/TEMP display: Shows coolant or room temperature. Also shows "AL" when the cooler is abnormal.
- SET/TEMP display: Shows fix or differential temperature when setting. Also will show alarm code AL-1(or -2 to -9).

Indicators:

- POWER: Green indicator, lights means power is on.
- PUMP: Green indicator, lights means pump is running.
- COOL: Green indicator, lights means compressor is running.
- ALARM: Red indicator, lights means the cooler is abnormal.

Operation:

Please check this cooler is at "Differential Temperature Mode" and "Fix Temperature Mode", and follow different setting process.

- Fix Temperature Mode: The LIQ/ROOM/TEMP display shows the coolant temperature, and SET/TEMP display shows the expect temperature. Press **▲** or **▼** button to increase or decrease setting temperature. For instance: if the LIQ/ROOM/TEMP display shows the coolant temperature is 30°C, but 25°C is the expected temperature. To press **▲** or **▼** button to make the SET/TEMP display shows 25°C, then the cooler will keep the coolant around 25°C.
- Differential Temperature Mode: The LIQ/ROOM/TEMP display shows the coolant temperature. SET/TEMP display shows expect differential temperature from room temperature. The cooler will keep the coolant temperature to the setting differential temperature compare to the room temperature.

IV Maintenance

In order to keep cooler cooling efficiency and prolong cooler lifetime, periodically maintenance is very important and necessary. Make sure to switch off the cooler main power before proceed any clean or maintenance action. Details as following:

- (1) If it is necessary to open the cooler guard for interior maintenance, please be sure to switch off the main power first, and avoid touching the fan and heat source to prevent any injury.
- (2) Please use neutral detergent or soap to clean the surface of the cooler. Do not use acid solvent to prevent corrosion on the case. Be careful not to make water spray to electronic parts to cause any damage.
- (3) Clean the filter net periodically. Spray off the dust with high-pressure air weekly. If the greasy dirt can't be removed by air, then use water and neutral detergent to wash it. (See Figure 17)
- (4) Use spraying air to clean the fins on the condenser. Make the high-pressure air through the fin by orthogonal direction.
- (5) The humidity might condense become water at the bottom of the reservoir, periodically vent the water and refill the coolant if necessary.
- (6) If there is any filter installed at the inlet or outlet, please clean and replace the filter periodically. (See Figure 18)

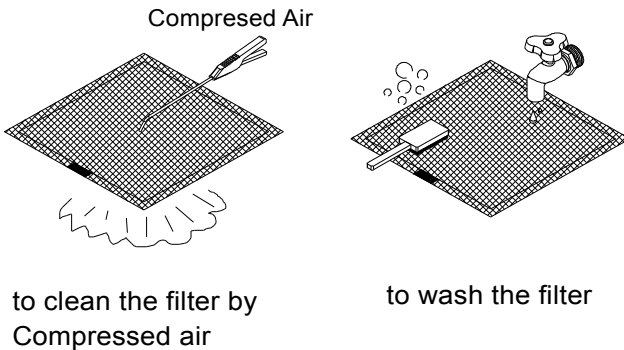

Figure 17

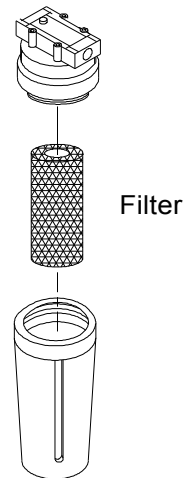

Figure 18

V Troubleshooting

All of the TAIWAN SPINFLO coolers passed fully test and quality control before shipped out from production line. However, if there is any unexpected trouble and problem happen, please contact with our agent with following information:

1. Model number and manufacturing number (can find these information on the cooler specification plate).
2. The alarm code shown on the display.

Chart 2 is the alarm message list.

Controller	Alarm Message		See Page
	Alarm Code	Alarm Reason	
SA Series	AL.1	Phase Reverse	P41 (5-1-1)
	AL.2	Pump Motor Abnormal	P42 (5-1-2)
	AL.3	Compressor Abnormal	P43 (5-1-3)
	AL.4	Room Temperature Sensor Abnormal	P45 (5-1-4)
	AL.5	Coolant Temperature Sensor Abnormal	P46 (5-1-5)
	AL.6	Coolant Temperature too High	P46 (5-1-6)
S Series	AL.1	Phase Reverse	P47 (5-2-1)
	AL.2	OPS Coolant pressure Abnormal	P48 (5-2-2)
	AL.3	Pump Motor Abnormal	P49 (5-2-3)
	AL.4	Compressor Abnormal	P49 (5-2-4)
	AL.5	Refreigent pressure Abnormal	P50 (5-2-5)
	AL.6	Room Temperature Sensor Abnormal	P50 (5-2-6)
	AL.7	Coolant Temperature Sensor Abnormal	P51 (5-2-7)
	AL.8	Coolant Temperature too High	P51 (5-2-8)
	AL.9	Coolant Temperature too Low	P51 (5-2-9)

Chart 2

Troubleshooting

Most of the troubles have to be solved by opening the top cover or open the door of the electric cabinet. There are 3 models of the electric cabinet: (1) door type (See Figure 19). (2) Front guard cover type (See Figure 20). (3) Top guard cover type (See Figure 21).

There is a thunder triangle label on the electric cabinet door.

Note: For safety reason, shut down the mail power before start any checking or maintenance.

Door type
(Figure 19)

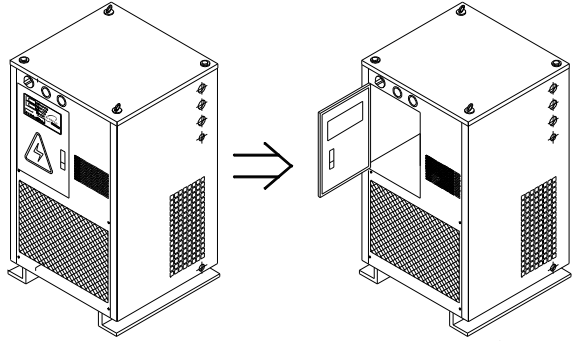

Front guard cover type
(Figure 20)

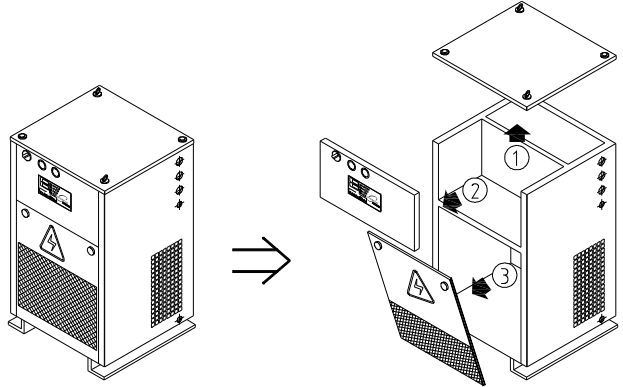

Top guard cover type
(Figure 21)

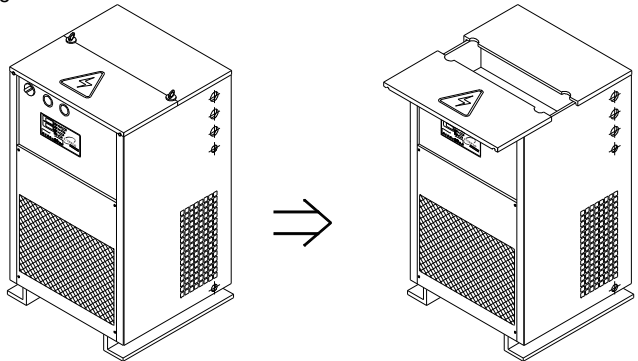

5-1. Single Temperature Display controller (SA series)

Alarms with alarm code (alarm indicator will light)

5-1-1 AL-1 Input voltage phase reverse or phase lack .

Possible Reason	Correct Action
Power phase reverse	Switch R/T power wire
Power voltage is too low	Voltage stabilizer is necessary
Check the 3P connector might get loose.	Power off. Tighten the connector.
RST tighten screws might get loose	Power off. Tighten the screw.
Circuit block breaks down.	Change a new circuit block.

Checking process and troubleshooting

- 1 \ Please refer to figure 19,20,21 to open the electric cabinet and to switch the R/T power wires. (See Figure 22)
- 2 \ Use multi-meter to measure the current and voltage to see If It's stable? (See Figure 23)

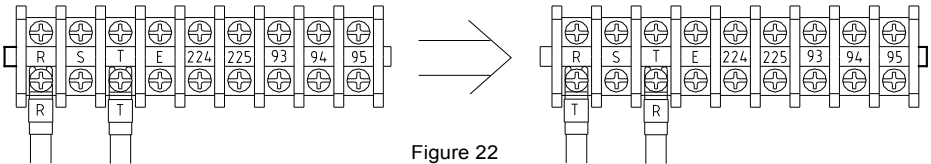

Figure 22

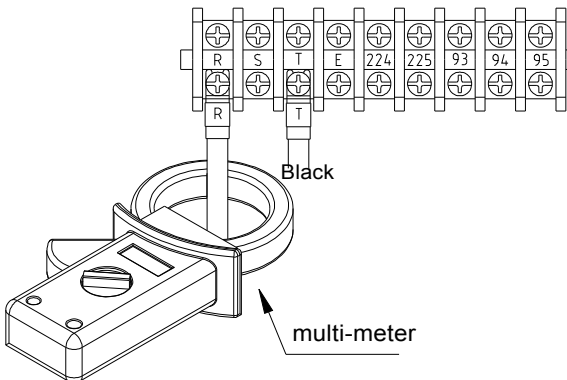

Figure 23

5-1-2 AL-2 Pump motor abnormal.

Please check if the motor stops after power on, it might be the pump motor overload.

Possible Reason	Correct Action
Thermal OL relay jumped off.	Reset the relay, and might adjust the current higher
Coolant suction pipe jam.	Clean the pipe or change a new filter.
Motor defect.	Change a new motor.
Load side contact abnormal.	Please make sure whether contact abnormal.
Outlet pipe jam or fold.	Please modification or change a new pipe.
Overload protector breaks down.	Change a new overload protector.

Checking process and troubleshooting

1、If the motor stop running because of the over current, please refer to figure 19,20,21 to find the 51P contactor to press "RESET" button, to restart the cooler. (See Figure 24)

Note: The thermostat position please refers to figure 11.

Figure 11

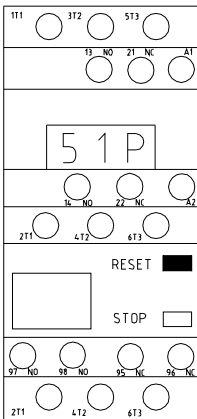
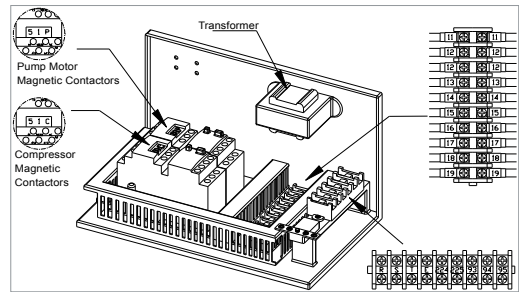
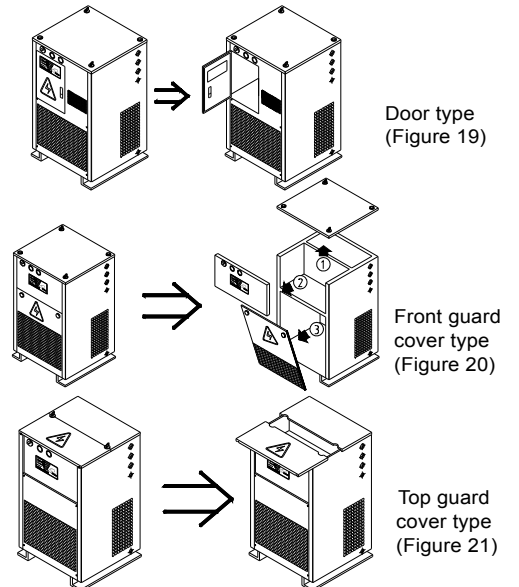

Figure 24

press "RESET"



Door type
(Figure 19)

Front guard
cover type
(Figure 20)

Top guard
cover type
(Figure 21)

5-1-3 AL-3 COMP (Compressor) and OPS (Oil Pressure Switch) switch: HP High pressure switch Compressor is abnormal or oil pressure is abnormal or refrigerant break down.

If the cooler stops after 6 seconds power on, this alarm should because of oil pressure abnormal.

Possible Reason	Correct Action
Thermal OL relay jumped off.	Reset the thermostat and adjust over load current go higher
Compressor break down.	change a new compressor.
Condenser is too dirty.	clean the condenser.
Condenser filter is too dirty.	clean the condenser filter.
Cooling fan is not running or fan is get loose.	Tighten the fan or change a new fan motor.
Refrigerant pressure switch break down.	Change a new refrigerant pressure switch.
Oil pressure switch break down.	Adjust the DIFF to 0.3 kgf/cm ² at range 0.5~0.8cmHg.
Condenser pressure too high.	Keep the cooler 50cm away from wall.
Inlet/outlet jam or connector gets loose.	Clean or tighten Inlet/outlet pipe
Inlet/outlet pipe reverse.	Switch the Inlet/outlet pipe
Pump motor phase reverse.	switch the red/white wire on thermostat (51 P)
Motor shaft wear, can't run pump.	Change the new motor or pump
Coolant is not enough.	Refill the coolant
Inlet pipe get loose.	Tighten the pipe.
Filter is too dirty.	Change a new filter.
Thermal OL relay jumped off.	Reset the thermostat, and might adjust the current higher
Coolant suction pipe jam.	Clean the pipe or change a new filter.
Motor break down.	Chang a new motor
Overload protector breaks down.	Chang a new overload protector

Checking process and troubleshooting

- 1 \ Please refer to figure 19,20,21 to find the 51C thermostat to press "RESET" button, to restart the cooler. (See Figure 25)
- 2 \ Open the rear cover, find the refrigerant pressure switch, and press "RESET" button. (See Figure 26)
- 3 \ If it's confirm that the alarm is from pressure switch, please take following check actions:
 - a. Check if any coolant flows into inlet, if no, check the coolant cycling system.
 - b. If the flow is normal, make connect 12/13 shorted. And if AL-3 still exists, contact you agent to change the controller.
 - c. Please refer to figure 28 to adjust the pressure switch setting after solve the AL-3 problem.
- 4 \ Use philips screwdriver to adjust the pressure switch. Take the bottom line of the indicator as reference, make the pressure setting to close to 0, don't lower than 0. Otherwise it will make the pressure too low. (See Figure 29)

Note: Please refer to (figure 11) to find the pressure switch position.

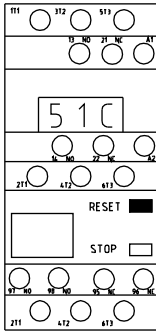

Figure 25

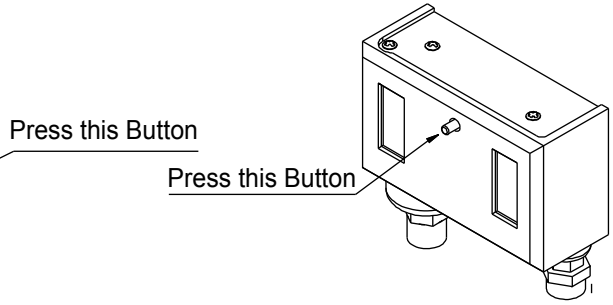

Figure 26

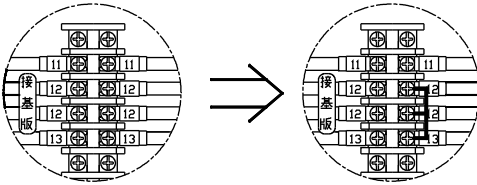

Figure 27

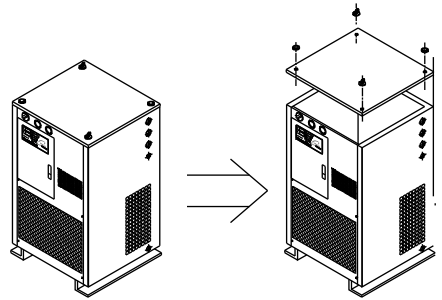

Figure 28

Take the bottom line of the indicator as reference.

Use the Philips screwdriver to do the adjustment

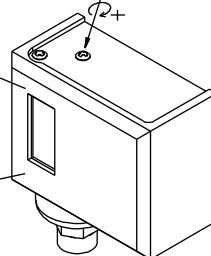
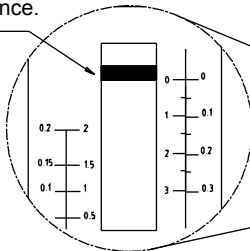

Figure 29

5-1-4 AL-4 RA (Room Temperature): Room temperature sensor abnormal.

Possible Reason	Correct Action
Room temperature sensor breaks down.	Change a new sensor.
Room temperature sensor wire gets loose on circuit block.	Tighten the screw of the wire.
Circuit block break down.	Change a new circuit block.

Checking process and troubleshooting

- 1、When AL-4 shows, switch 20/21 and 22/23 wires (See Figure 30-1, 30-2), after this action, if still shows AL-4, then please contact your agent to change the controller.
- 2、If after switch 20/21 and 22/23 wires, the alarm code change to AL-5, it means sensor is broken, please contact your agent to change the sensor.

Note: 20/21 are the wires of coolant temperature sensor. 22/23 are the wires of the room temperature sensor.

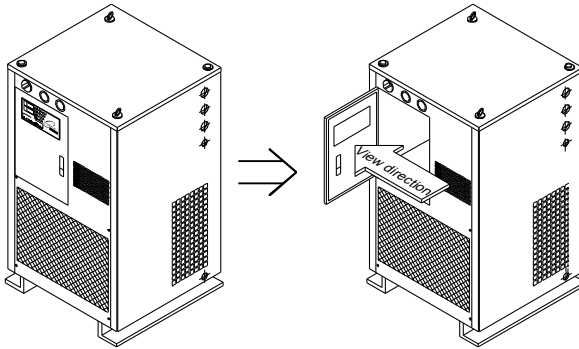

Figure 30-1

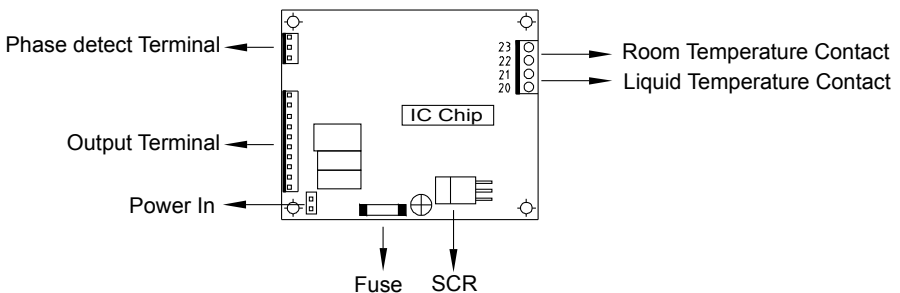

Figure 30-2

5-1-5 AL-5 RO(Liquid Temperature) Coolant temperature sensor abnormal.

Possible Reason	Correct Action
Coolant temperature sensor breaks down.	Change a new sensor.
Coolant temperature sensor wire gets loose on circuit block.	Tighten the screw of the wire.
Circuit block breaks down.	Change a new circuit block.

Checking process and troubleshooting

1 \ When alarm AL-5 shows, switch 20/21 and 22/23 wires (See Figure 30-1, 30-2), after this action, if still shows AL-5, then please contact your agent to change the controller.

2 \ If after switch 20/21 and 22/23 wires, the alarm code change to AL-4, it means sensor is broken, please contact your agent to change the sensor.

Note: 20/21 are the wires of coolant temperature sensor. 22/23 are the wires of the room temperature sensor.

5-1-6 AL-6 OT(Over Temperature) Coolant temperature is too high.

Possible Reason	Correct Action
Coolant temperature too high.	Stop the cooler until the coolant cool down.
Refrigerant is not enough in system	Change a new sensor, refill the refrigerant.
Coolant temperature sensor breaks	Change a new sensor.
Compressor not running.	Please check circuit block.
Compressor contactor break down.	Change a new thermostat.
Compressor overload protector breaks down.	Change a new overload protector.
Refrigerant brown out. Freon not enough.	Please check pressure and electric current \ whether to fit a criterion.

Checking process and troubleshooting

Please refer to 5-1-5 AL-5, take the same action to do the troubleshooting.

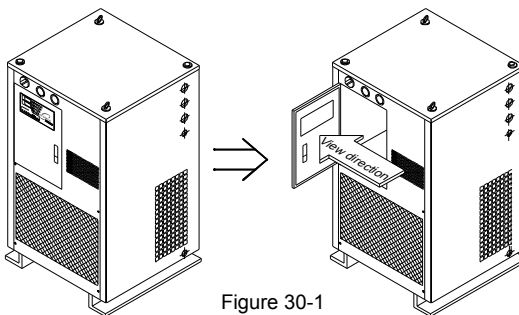

Figure 30-1

(2) Alarm without alarm code

■ POWER indicator didn't light.

Possible Reason	Correct Action
Power indicator lines get loose.	Tighten the screw of the power lines
Controller transformer burns out.	Change a new transformer.
Fuse on the controller burns out.	Change a new fuse.
Power Indicator burns out	Change a new controller.
Wire 224/225 not properly shorted.	Put on the short circuit plate on 224/225 or connect to machine.

Checking process and troubleshooting

Note: Please refer to Figure 30-1 and 30-2 to find the power-line and fuse position.

5-2. Two-temperature display controller (S series)

(1) Alarms with alarm code (alarm indicator will light)

5-2-1 AL-1 Input voltage phase reverse or phase lack .

Possible Reason	Correct Action
Power phase reserve.	Switch R/T power wire.
Power voltage is too low.	Voltage stabilizer is necessary
Check the 3P connector might get loose.	Power off. Tighten the connector.
RST tighten screws might get loose	Power off. Tighten the screw.
Circuit block breaks down.	Change a new circuit block.

Checking process and troubleshooting

Please refer to 5-1-1 AL-1 correct actions.

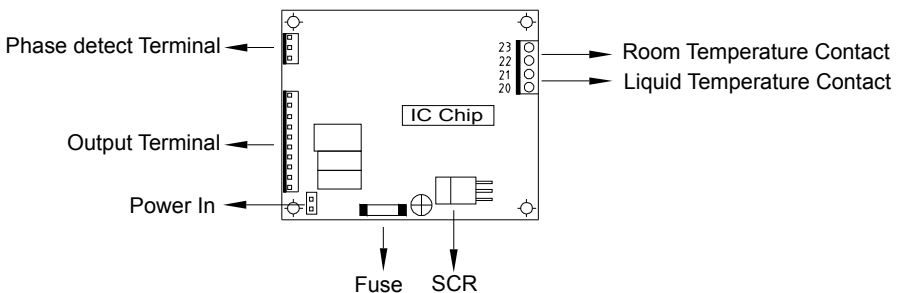

Figure 30-2

5-2-2 AL-2 OPS(Oil Pressure Switch) : Coolant pressure abnormal.

Possible Reason	Correct Action
Inlet/outlet jam or connector gets loose.	Clean or tighten Inlet/outlet pipe.
Inlet/outlet pipe reverse.	Switch the Inlet/outlet pipe.
Pump motor phase reverse	Switch the red/white wire on relay (51 P)
Motor shaft wear can't run pump.	Change the new motor or pump.
Coolant Is not enough	Refill the coolant.
Inlet pipe get loose.	Tighten the pipe.
Filter is too dirty.	Change a new filter.
Oil pressure switch break down.	Adjust the DIFF to 0.3 kgf/cm ² at range 0.5~0.8cmHg.
There are bubble in hydraulic tube.	Hydraulic pump must be to exhaust .
Motor defect.	Change the new motor.

Checking process and troubleshooting

- 1 \ Please refer to figure 31 to confirm inlet and outlet position.
- 2 \ Check if any coolant flows into inlet pipe. (See Figure 32)
- 3 \ If it's confirm that the alarm is from pressure switch, please take following check actions:
 - a. Check if any coolant flows into inlet, if no, check the coolant cycling system.
 - b. If the flow is normal, make connect 12/13 shorted (See Figure 27). And if AL-2 still exists, contact you agent to change the controller.
 - c. Please refer to figure 28 to adjust the pressure switch setting after solve the AL-2 problem.
- 4 \ Use Philips screwdriver to adjust the pressure switch. Take the bottom line of the indicator as reference, make the pressure setting to close to 0, don't lower than 0. Otherwise it will make the pressure too low.

Note: Please refer to figure 33 to find the pressure switch position.

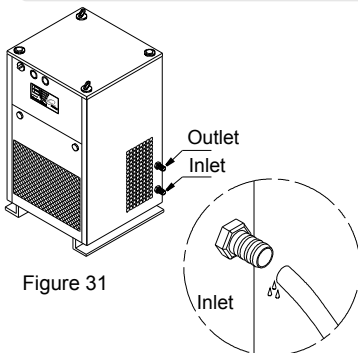

Figure 31

Figure 32

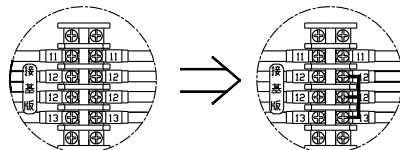

Figure 27

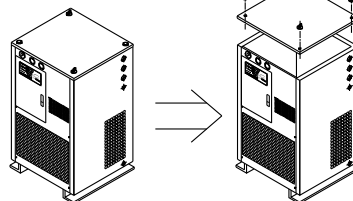

Figure 28

Take the bottom line of the indicator as reference.

Use the Philips screwdriver to do the adjustment

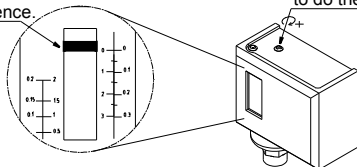

Figure 33

5-2-3 AL-3 PUMP motor : Pump motor abnormal.

Possible Reason	Correct Action
Thermal OL relay jump off	Reset the contactor, and might adjust the current higher.
Coolant suction pipe jam.	Clean the pipe or change a new filter.
Motor defect.	Change a new motor.
Load side contact abnormal.	Please make sure whether contact abnormal .
Outlet pipe jam or fold.	Please modification or change a new pipe.
Overload protector breaks down.	Change a new overload protector.

Checking process and troubleshooting

Please open power distribution box See Figure 26.(refer to figure 19,20,21) to find the 51P contactor, and press "RESET" button. (See Figure 25.)

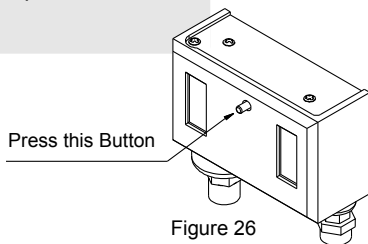

Figure 26

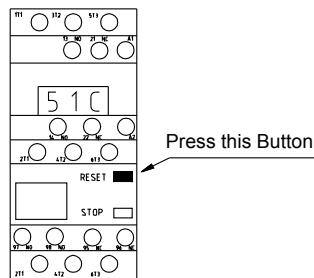

Figure 25

5-2-4 AL-4 COMP(Compressor) : compressor abnormal

Possible Reason	Correct Action
Thermal OL relay jump off.	Reset the thermostat and adjust over load current higher
Compressor breaks down	change a new compressor
Load side contact abnormal	Please make sure whether contact abnormal
Please make sure the input voltage value or in unstable status.	Please modify the input voltage value and keep to stabilize.
Overload protector breaks down.	Change a new overload protector

Checking process and troubleshooting

1 \ Please refer to figure 19,20,21 to find the 51C contactor, and press "RESET" button. (See Figure 25.)

Troubleshooting

5-2-5 AL-5 HP (High Pressure) refrigerant pressure abnormal.

Possible Reason	Correct Action
Condenser is too dirty.	Clean the condenser.
Condenser filter is too dirty.	Clean the condenser filter.
Cooling fan is not running or fan is get loose.	Tighten the fan or change a new fan motor.
Refrigerant pressure switch break down.	Change a new refrigerant pressure switch.
Condenser pressure too high.	Keep the cooler 50cm away from wall.
Froen is not enough in system.	Contact you agent.

Checking process and troubleshooting

Open the rear cover, find the refrigerant pressure switch, and press "RESET" button. (See Figure 26)

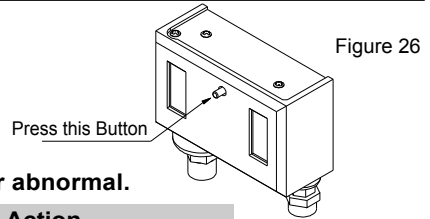

Figure 26

5-2-6 AL-6 RA(Room Temperature) sensor abnormal.

Possible Reason	Correct Action
Room temperature sensor breaks down.	Change a new sensor.
Room temperature sensor wire gets loose on circuit block.	Tighten the screw of the wire.
Circuit block breaks down.	Change a new circuit block.

Checking process and troubleshooting

Please refer to 5-1-4 AL-4, Room temperature sensor abnormal.

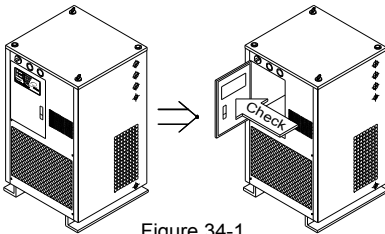

Figure 34-1

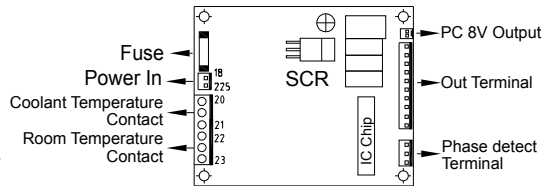

Figure 34-2

5-2-7 AL-7 RO(Liquid Temperature):Coolant temperature sensor abnormal.

Possible Reason	Correct Action
Coolant temperature sensor breaks down.	Change a new sensor.
Coolant temperature sensor wire gets loose on circuit block.	Tighten the screw of the wire.
Circuit block breaks down.	Change a new circuit block.

Checking process and troubleshooting

Please refer to 5-1-5 AL-5, take the same action to do the troubleshooting.

5-2-8 AL-8 OT(Over Temperature): coolant temperature is too high

Possible Reason	Correct Action
Coolant temperature too high.	Stop the cooler until the coolant cool down.
Freon leakage.	Refill the freon.
Coolant temperature sensor breaks down.	Change a new sensor.
Compressor not running.	Please check circuit block.
Compressor thermostat break down.	Change a new thermostat.
Compressor over load protector break down.	Change a new over load protector.
Freon is not enough.	Please check pressure and electric current whether to fit a criterion.

5-2-9 AL-9 LT (Low Temperature): coolant temperature is too low.

Possible Reason	Correct Action
Coolant temperature too low.	Stop the cooler until the coolant temperature back.
Coolant temperature sensor breaks down.	Change a new sensor.
Compressor control circuit block abnormal.	Check circuit block abnormal.
Compressor magnetic contactor break down.	Change a new contactor.
Compressor over load protector break down.	Change a new over load protector.

Checking process and troubleshooting

Please refer to 5-1-5 AL-5, take the same action to do the troubleshooting.

(2) Alarm without alarm code:

■ POWER indicator didn't light.

Possible Reason	Correct Action
18/225Power indicator lines get loose.	Tighten the screw of the power indicator lines.(18/225)
Controller transformer burns out.	Change a new transformer.
Fuse on the controller burns out.	Change a new fuse.
Power Indicator burns out.	Change a new controller.
Wire 224/225 not properly shorted.	Put on the short circuit plate on 224/225 or connect to machine.

Checking process and troubleshooting

Note: Please refer to Figure 34-1 and 34-2 to find the power-line and fuse position.

售後服務保證書

親愛的客戶：

感謝您使用本公司生產之工業用冷卻機系列，為了使冷卻機能長期正常運作減少故障率產生，在冷卻機使用前請詳閱本操作手冊，了解冷卻機的特性，以增加冷卻機之效果，敬請正確使用。

一、注意事項：

- 1-1 請注意定期清理過濾網之灰塵（若落塵量大，請增加次數）。
- 1-2 若冷卻機經搬動，請半小時後再通電，以免壓縮油滲漏，阻塞毛細管。
- 1-3 保固期限：自出廠日起一年內(不包括天災損害及人為不當使用，如：不按操作手冊操作或不清理過濾網等)。

二、以下事項在保證期間內，若發生故障，本公司維修將酌收工本費：

- 2-1 若未依照台灣旋流公司之操作手冊事項操作而導致機械毀損，不在此保固內。
- 2-2 使用非本公司提供之零組件或非由本公司維修而引起之故障。
- 2-3 耗材(如冷媒CFC-R134、R22、過濾器、濾心、過濾網、回油過濾器)。
- 2-4 機器因天災及人為不可抗力(如暴動、戰亂等)之原因損壞。
- 2-5 因電力不足或高壓放電對本機造成之損壞。
- 2-6 在本操作手冊所指之使用範圍以外。
- 2-7 由於其他機械故障，以致引起本冷卻機在使用中所引起之二次故障。
- 2-8 由於運送及裝訂木箱不當而造成本機損壞。

三、本機之保證限在中華民國。

四、本保證書須加蓋公司印章，且註明機型機號，方得生效。

五、本保證書塗改無效，請妥為保存。遺失恕不補發。

六、服務專線:(04)23399768 傳真:(04)23392768

七、本機品名：

本機機號：

出廠日期： 年 月 日

八、客戶名稱：

住址：

電話：



※請填好上列資料，傳真回本公司，建立客戶服務檔案。

Thanks for choosing TAIWAN SPINFLO coolers. Please read this instruction manual carefully before operation, to ensure correct operation to prolong machine running time.

1. Points for attention:

- 1-1 Clean the condenser filter net according to maintenance manual. (If the cooler located in dusty area, please to increase cleaning frequency.)
- 1-2 Leave the cooler alone for at least 30 minutes, then connect the power. This action is to prevent the refrigerant liquid get into the compressor and capillary tube to cause damage.
- 1-3 Warranty period: It starts within one year after leaving the factory (not including damages resulted from disaster or improper operation, such as: did not follow standard operation procedures, or not clean the filter...etc.)

2.The following conditions exempt us from our repair service free of charge this warranty stipulates.

- 2-1 Any damage resulted from not following TAIWAN SPINFLO operation manual.
- 2-2 Failure happens because of not using original TAIWAN SPINFLO parts or repair the cooler not by TAIWAN SPINFLO authorized technician.
- 2-3 Consumptive parts or materials. Such as: R134/R22 refrigerant, air filter, oil filter...etc.)
- 2-4 Machines are damaged due to disasters or unexpected condition (such as: riots or war).
- 2-5 Machines are damaged due to Insufficient power Input or high voltage shock.
- 2-6 Using this unit beyond the working range as the Instruction manual specified.
- 2-7 The failure or damage Is cause by the failure of connected machine tool.
- 2-8 Machines are damaged due to Inappropriate handing and crating.

3.This warranty is effective and valid only if this unit is purchased and operated in Taiwan.

4.This warranty card is void If without TAIWAN SPINFLO company stamp.

5.The warranty card is void for without TAIWAN SPINFLO authorized alteration In the content.

6.Service phone Number:TEL:**+886-4-23399768** FAX:**+886-4-23392768**

7.Machine model number:

Machine series number:

Date of production:

8.Name of customer:

Address:

Tel:



Please fill out this form and fax this back to TAIWAN SPINFLO.



413 台中縣霧峰鄉丁台路780號

TEL:04-23399768 FAX:04-23392768

E-mail: taiwan.spinflo@msa.hinet.net

No.780, Dingtai Rd., Wufeng Shiang, Taichung
County 413, Taiwan R.O.C.

TEL:886-4-23399768 FAX:886-4-23392768

E-mail:taiwan.spinflo@msa.hinet.net

半導體工業 Semiconductor Industry

高科技產業 Advanced Scientific & Technical Industry

生物科技 Bio-Technology

醫療機構 Medical Institutions

傳統機械產業 Traditional Machinery Industry

學校政府單位 Schools and Public Agencies